



The Parker Ranch installation in Hawaii

# Solar Energy Technology Program Distributed Grid Integration Activities

December 9, 2010

**Kevin Lynn**

Systems Integration Team Lead  
Solar Energy Technology Program

## Distributed Grid Integration

- Vision
- Mission
- SNL FY 2011 Activities
- NREL FY 2011 Activities
- HCEI
- HiPen Projects
- SEGIS



- There will be a well established, timely and cost effective process for integrating high penetrations of PV into utility distribution systems while providing maximum value to the PV system owner and utility.
- 2012 – 2016 targets toward the goal of meeting 10-20% solar energy penetration by 2030

FY 2011	FY 2012 <sup>1</sup>	FY 2013	FY 2014	FY 2015	FY 2016
<b>Performance Measure:</b> Provide technologies and integration strategies that enable >20% annual PV energy penetration (100% peak capacity penetration) into two types of distribution feeder circuits, in support of achieving the Solar Vision Goal of 10-20% of electricity demand from solar energy by 2030. <sup>2,3</sup>					
T: NA A:NA	T: >4%* solar energy penetration into 2 types of distribution feeder circuits A:	T: >6% solar energy penetration into 2 types of distribution feeder circuits A:	T: >10% solar energy penetration into 2 types of distribution feeder circuits A:	T: >15% solar energy penetration in 2 types of distribution feeder circuits A:	T: >20% solar energy penetration in 1 type of distribution feeder circuit A:

- To reach our vision of integrating high penetrations of solar in a safe, reliable, and cost effective way through

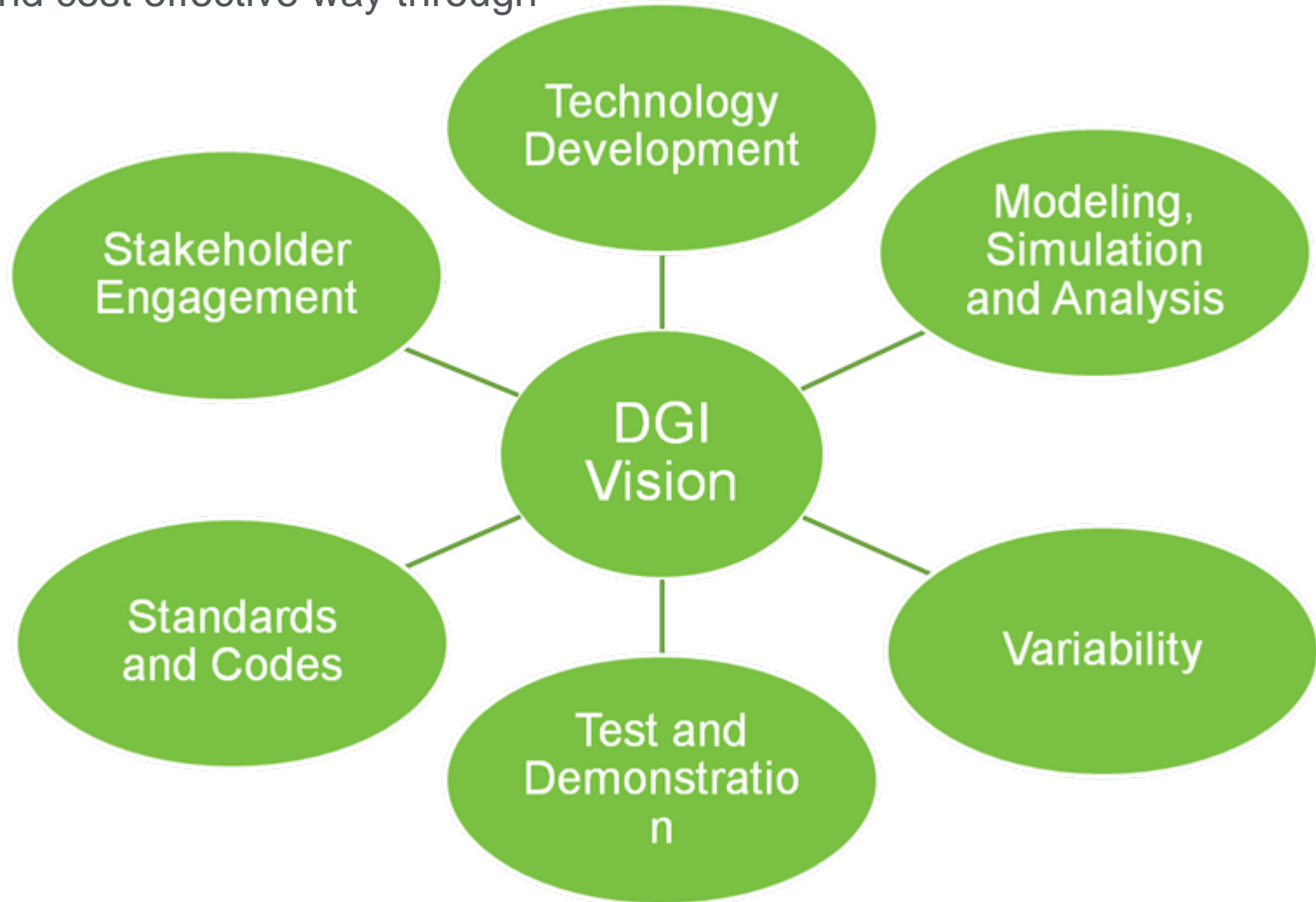

# Solar Energy Grid Integrations Systems (SEGIS)

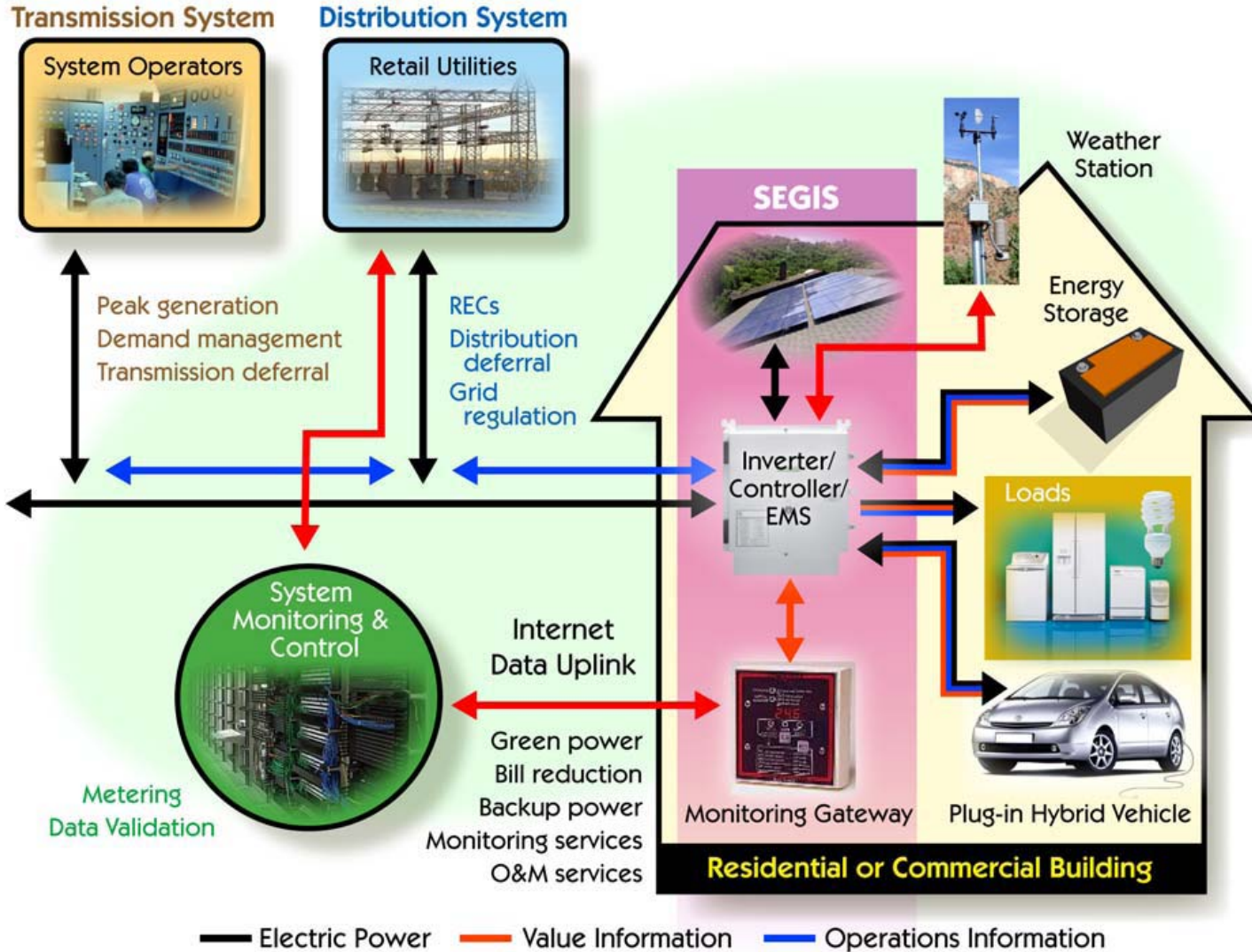

## SEGIS Stage 3 Downsized from five to four Contractors

Lead Company	Short Project Title
Apollo Solar	Advanced Grid-tied Inverter, Charge Cont, Energy Monitor, Internet Gateway
EMTEC	SEGIS - Emerson PV Inverter Development
Enphase	Nano-inverters with VARControl and EMS
GE	Grid Integration of High-penetration Solar Energy
Nextek Power Sys	PV Interface Providing Concurrent AC & DC Power Network Support
Petra Solar	Economically Viable, Highly Integrated, Highly Modular SEGIS Architecture
Premium Power	Intelligent PV Inverter
Princeton Power	Demand Response Inverter
PV Powered	MPPT and EMS Advancements
Smart Spark	Alternating Current PV Module with System Interface
U Central FL –FSEC	Grid-Smart Inverters
VPT Inc	Inverter Cont Card (ICC), Bidirectional Power Conversion(BPC), Power Hub Control (PHC), Integrated Power Hub (IPH)

# Economically Viable, Highly Integrated, Highly Modular SEGIS Architecture (Petra Solar)

## Technologies Addressed

Smart Grid Interconnection, System Cost, Modularity, System Reliability, Safety, and Advanced Scalable Inverters.

## Description

Petra Solar and its team will advance grid interconnection, cost reductions, system reliability, and safety through low cost, easy-to-install, modular and scalable inverter power architectures that are scalable from 5kW to 20kW. Advances include multi-layer control, communication architecture, monitoring and controlling a cluster of AC module inverters, and a strategic EMS switch junction box.

## Resources (\$)

DOE Total	DOE Stage 1	Cost Share (total)
\$6,250K	\$250K	20% - 20% - 50%

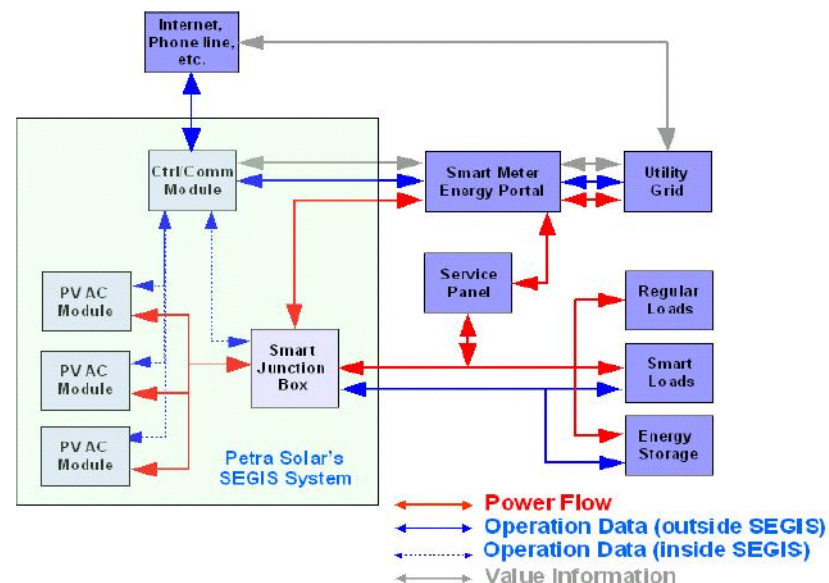

## Participants

### Lead

### Petra Solar

### Adje Mensah

Florida Power  
Electronics Center

Florida Solar  
Energy Center

Lakeland Electric  
Echelon  
BP Solar  
Evergreen Solar



# Demand Response Inverter (Princeton Power Systems)

## Technologies Addressed

Demand Response Inverter, Load Control, Energy Storage, High Efficiency Components, Grid Integration.

## Description

Princeton Power's team will develop a complete design for a 100-kW "Demand Response Inverter" based on its unique inverter technology. The design will be optimized for low-cost, high-quality manufacture, and will integrate control capabilities including dynamic energy storage and demand response through load control.

## Resources (\$)

DOE Max (3 stages)	DOE Stage1 (max)	Cost Share per stage
<b>\$6,250K</b>	<b>\$250K</b>	<b>20% - 20% - 50%</b>

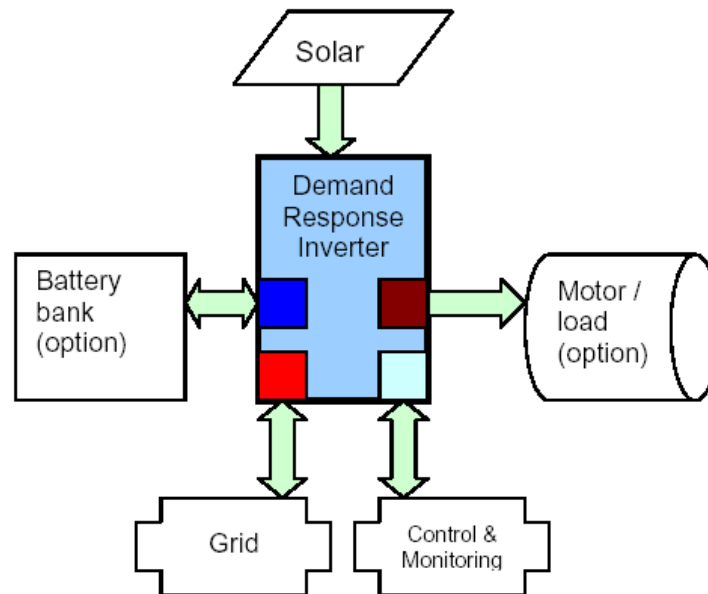

## Participants

### Lead

Princeton Power Systems, Inc.

TDI Power Corp.

Worldwater and Solar Technologies

Mark Holveck  
Darren Hammell

Gaia Power Technologies



# Maximum Power Point Tracking, Advanced EMS and Utility Integration (PVPowered)

## Technologies Addressed

Optimized Performance Algorithms, Advanced Data Collection, Communications and Energy Management Systems (EMS).

## Description

PV Powered and its team will develop a suite of maximum power point tracking (MPPT) algorithms to optimize energy production from the full range of available and emerging PV module technologies. The work will also develop integration of communications with facility energy management systems and utility grid management networks.

## Resources (\$)

DOE Max (3 stages)	DOE Stage1 (max)	Cost Share per stage
<b>\$6,250K</b>	<b>\$250K</b>	<b>20% - 20% - 50%</b>



## Participants

### Lead

Portland  
General Electric

### PVPowered

South Dakota  
State University

Dr. Steve  
Hummel

Northern Plains  
Power  
Technologies

**PVPowered™**  
*Simply More Reliable Solar*

# Development, Validation and Commercialization of Grid-Smart Inverters for Wider PV Technology Utilization (Florida Solar Energy Center at UCF)

## Technologies Addressed

Utility Control of Enhanced Inverter Features, Disturbance-tolerant Anti-Islanding, Shared Inverter, Energy Storage, Building Interaction.

## Description

The FSEC and UCF team will develop new concepts and enhance “Smart Grid” development. A “shared” inverter serving multiple residential or commercial PV arrays located at a distribution transformer will be developed. Work includes battery storage, utility control, communication, monitoring, or building energy management systems (BEMS). An “anti-islanding” strategy that allows PV on line during grid disturbances will improve grid stability. New inverter architectures will bring more stability to the grid.

## Resources (\$)

DOE Max (3 stages)	DOE Stage1 (max)	Cost Share per stage
<b>\$6,250K</b>	<b>\$250K</b>	<b>20% - 20% - 50%</b>

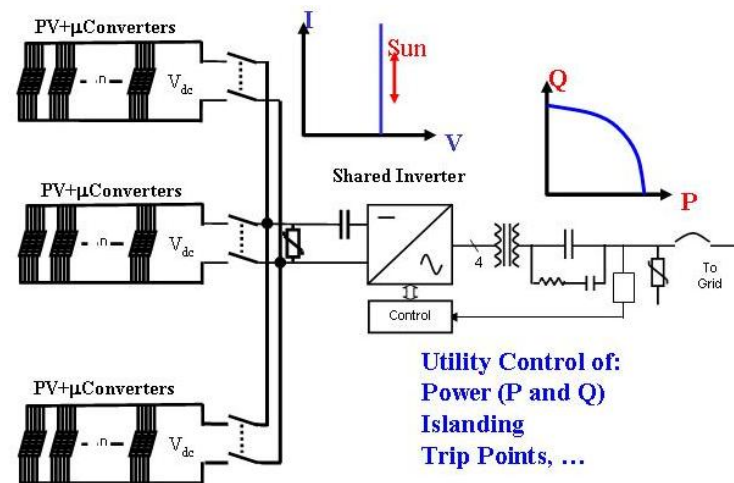

## Participants

Lead	Participants	Participants
University of Central Florida Robert Reedy (FSEC/UCF)	SatCon	Northern Plains Power Technologies
	SENTECH Inc.	
	EnFlex	Lakeland Electric Utilities
	SunEdison	



- **High Penetration Solar Deployment Awards**
  - Arizona Public Service
  - Commonwealth Edison (Illinois)
  - Florida State University
  - NREL-Southern California Edison
  - Sacramento Municipal Utility District
  - Univ. of California – San Diego

- Study the effects of large amounts of distributed PV on a utility feeder and it's associated customers
- Create and validate models to describe the interactions between weather/PV/feeder equipment and operations
- Identify technical and operational modifications that could be deployed in future feeder designs.

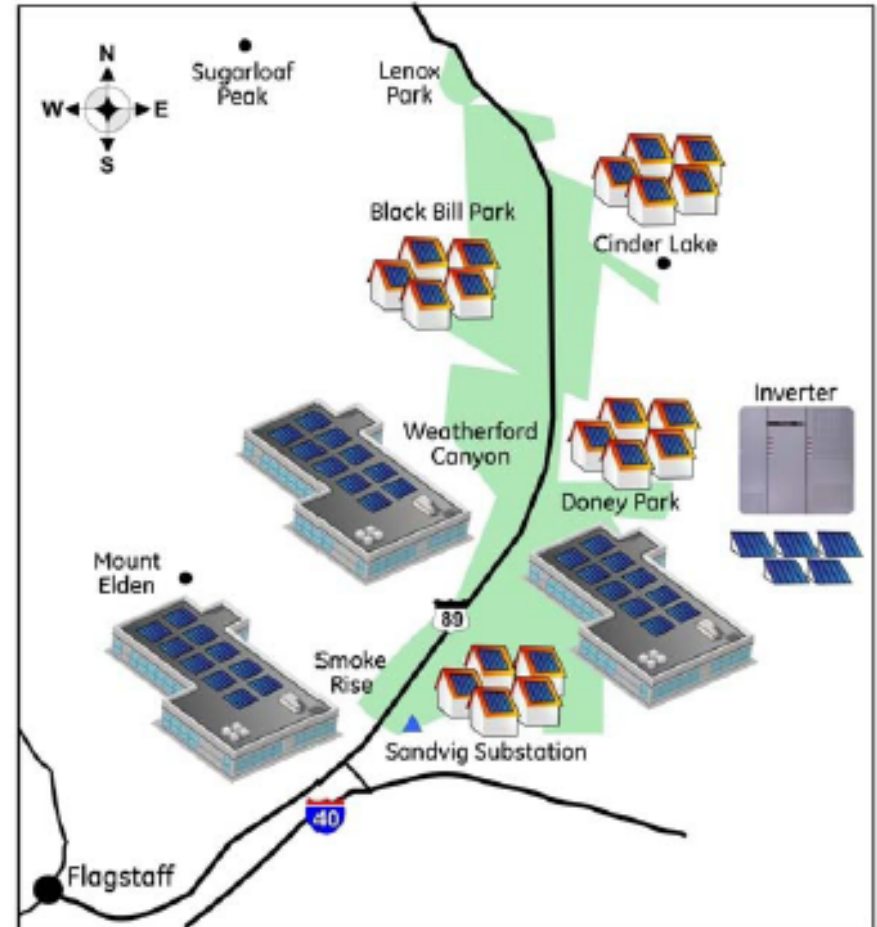

- Power Analytics for Development and Validation of Steady State and Dynamic Models of PV Systems
- Solar Resources and Integration of Energy Storage and PV as an “Enabler Technology”
- Cloud Tracking and Insolation Forecast Model
- Command, Control and Communications for Power Flow Management
- Field Testing and Validation of the Suite of Models
- Raise Situational Awareness of Virtual Power Plants and Microgrids by Distribution Utilities and RTO/ISOs





SCE  
MW scale  
rooftop  
installation

- SCE is installing 500MW of commercial rooftop PV systems over the next 5 years
- 250MW utility owned, 250MW IPP
- Interconnected at distribution circuit level

## Specific Issues:

- Unsure of interconnection process for circuits with over 15% PV (Peak PV/Peak Load)
- Need to develop quick study process for penetrations >15%
- Issues include: voltage regulation, circuit ratings, circuit protection coordination, cloud variability

# SMUD PV & Smart Grid Pilot at Anatolia

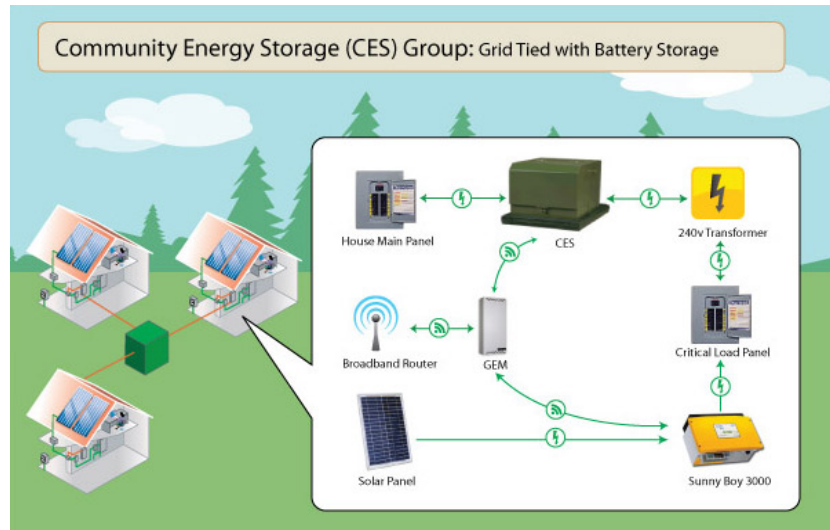
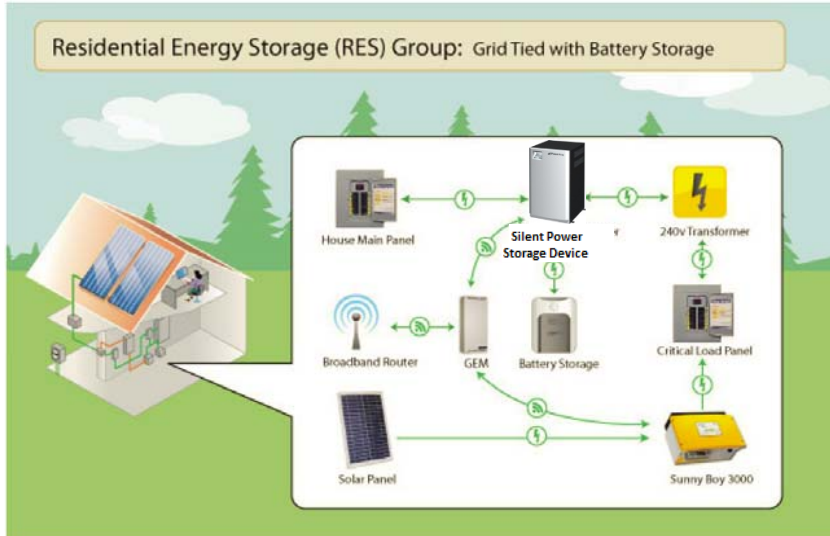

- US DOE, Energy Efficiency and Renewable Energy Office funded project
- Partners include GridPoint, SunPower, Navigant, NREL
- Will firm renewables, reduce peak load and improve reliability
- Installing 15 RES and 3 CES units in Anatolia SolarSmart<sup>SM</sup> Homes that currently have 2kW PV systems
- Installing utility and customer portals to monitor PV, storage, customer load
- Sending price signals to affect changes in customer usage
- Developing specification for smart meter/inverter interface to enable management of distributed PV/storage system with AMI
- Quantifying costs and benefits of this storage deployment to gain insights to broader application for SMUD

- Grid Integration Support and Collaboration
  - Systems Level Testing
  - Technical Systems Modeling and Simulation
  - HCEI – Distribution System Analysis
- 
- Activities closely coordinated with Sandia (complementary)

- **Grid Integration Support and Collaboration**
  - Complete a second special issue of *IEEE Power & Energy Magazine* developed entirely to Solar Energy Integration
  - Support U.S. representation on the International Energy Agency (IEA) PVPS Task 11: PV Hybrid-Minigrids Group
  - Support U.S. representation on the new IEA PVPS Task 14 on High-Penetration of PV Systems in Electricity Grids

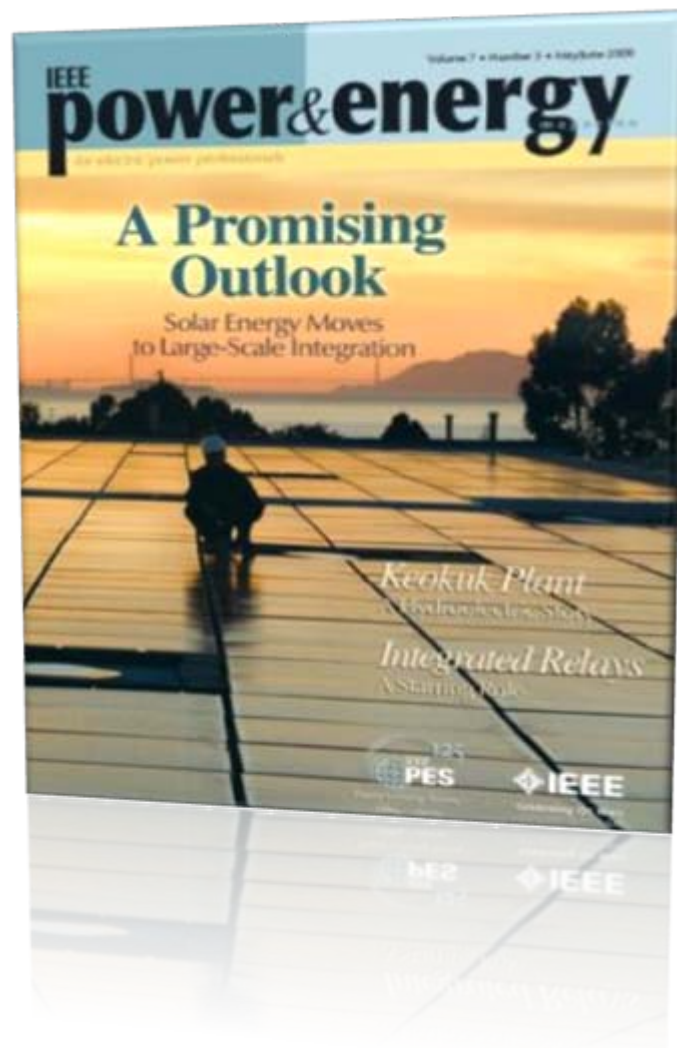

## • Systems Level Testing

- Continue working with SMUD on their Anatolia III Solar Subdivision and with Xcel Energy/SunEdison on the Alamosa system
- Data from these systems will help identify potential issues with large penetrations of PV on distribution feeders as well as quantify the effect these systems are having on actual operating electrical distribution systems

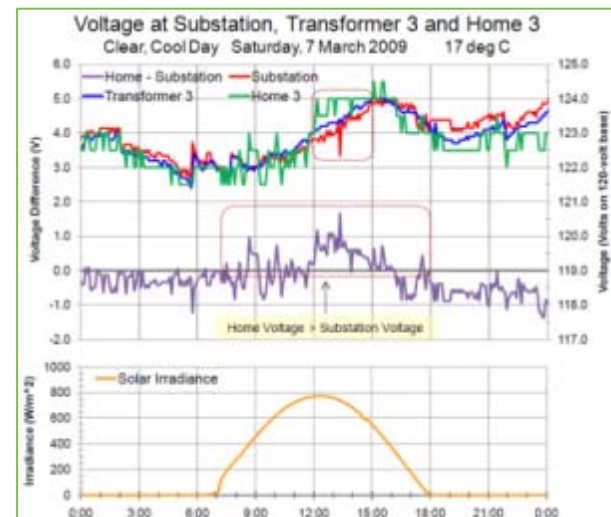

## • Technical Systems Modeling and Simulation

- developing analysis, modeling, and simulation tools and conducting technical analysis on high penetration scenarios for PV systems and their impact on the electric power system
- develop enhanced component and system models for distributed renewable energy systems (sources, energy storage units, etc.)
- development of visualization techniques for understanding high penetration PV scenarios at the distribution level

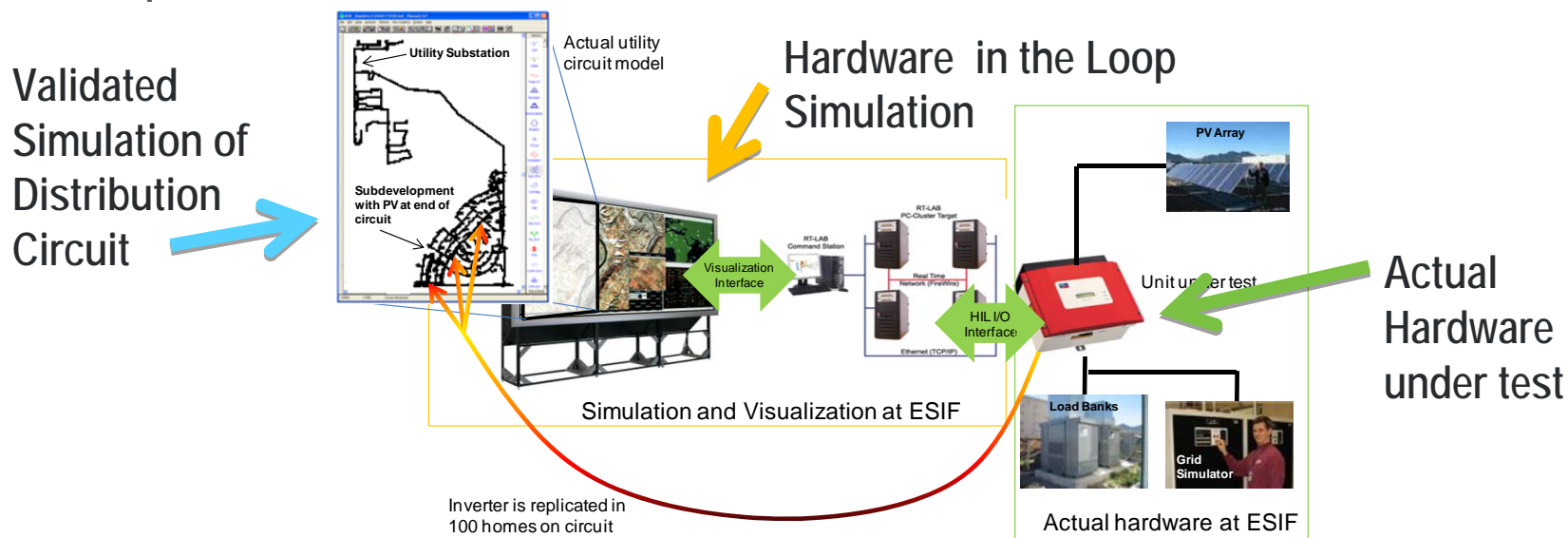

- Hawaii Clean Energy Initiative

- Distribution-Level PV Penetration study with HECO
- Solar Resource Characterization for System Integration Studies
- Oahu and Maui Renewable Integration Studies
- Technical Review Committees for Integration Studies

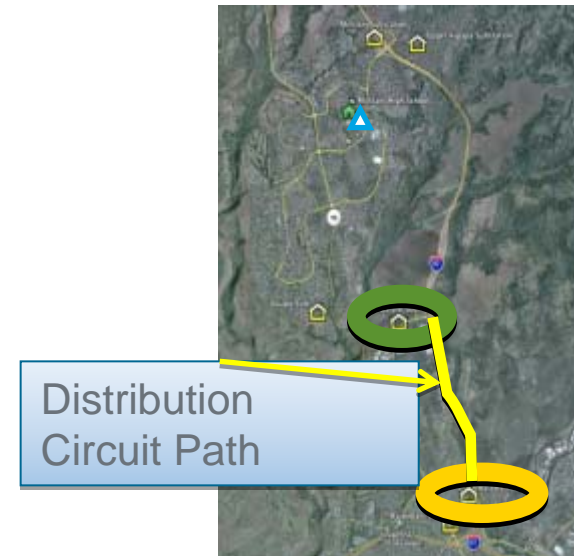

- Industry Engagement
- System Level Test and Evaluation
- Distribution System Analysis
- Technology Development

Activities closely coordinated with NREL (complementary)

- PV Feeder Analysis
  - Evaluate impact of high penetration PV on different Feeders
  - Collaborate with EPRI, use OpenDSS software (open source)
  - Refine grid models and use better PV variability data
- Analysis of PV operation with Smart Grid applications
  - Analyze operation of PV as part of several Smart Grid demonstration projects in New Mexico
    - Mesa Del Sol (600 kW of PV) demonstrating PV ramp rate control, peak shaving and intentional islanding
    - Los Alamos PV Microgrid (1 MW PV) demonstrating variability mitigation, demand response, voltage control
  - Analyze 2 years on 1-second data from Ota City (very high penetration PV on distribution feeder) and application of lessons learned to US distribution-connected systems

- Data Collection at Lanai

- Collect data and document operation with energy storage system installed and PV system at full output
- Obtain and publish data from several distribution-connected systems (OG)

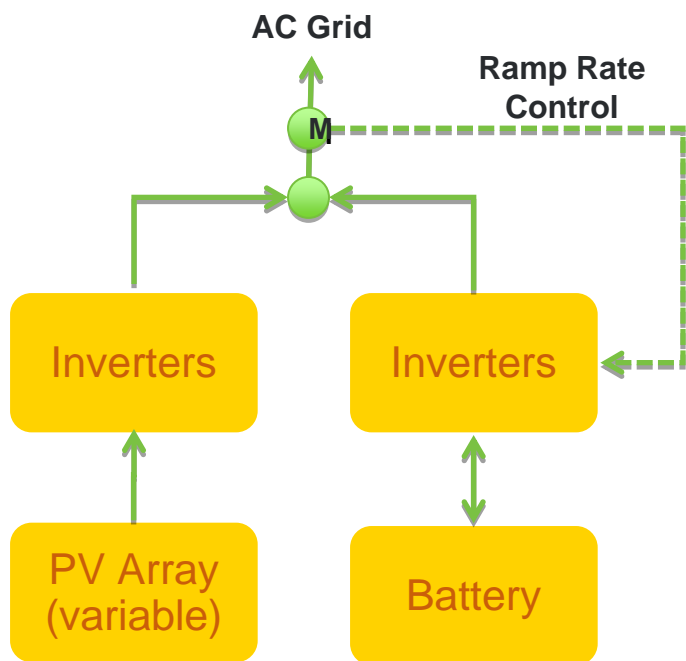

Analysis of Frequency Impact

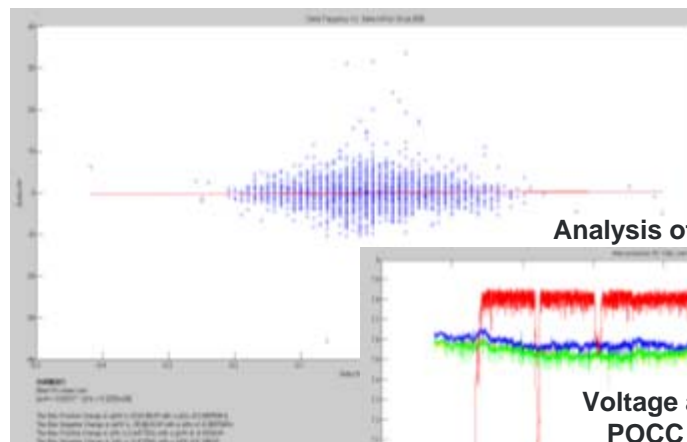

Analysis of voltage impacts

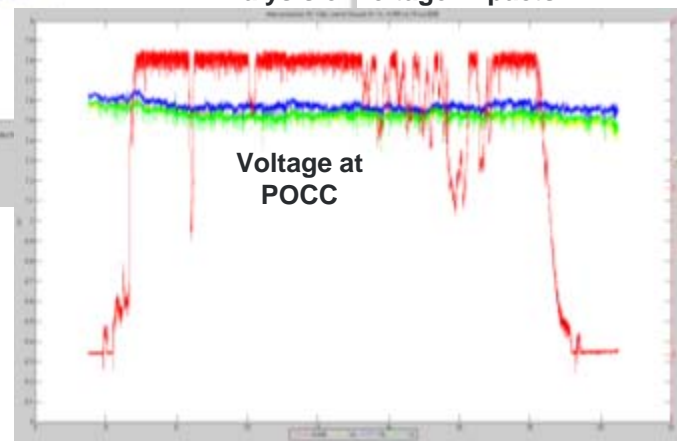

- Stakeholder Engagement: Participate in information dissemination and technical coordination activities related to distribution grid integration
  - SEPA Grid Integration Interest Group, UWIG Solar Users Group, EPRI distributed PV solar program activities
  - Direct engagement with utilities

# Thank You



## Questions