

**IMPACT OF DISTRIBUTED SOLAR  
ON SMUD'S PEAK LOAD AND  
LOCAL DISTRIBUTION SYSTEM**

**4<sup>th</sup> International Conference on  
Integration of Renewable and Distributed  
Energy Resources  
Dec 6-10,2010  
Albuquerque, NM**

**Mike Keesee**  
Project Manager  
ER&D  
SMUD



**SMUD**

SACRAMENTO MUNICIPAL UTILITY DISTRICT

The Power To Do More.<sup>SM</sup>

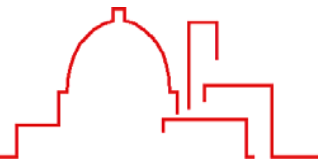

- Premier Gardens Study
- Anatolia Master Plan Community Study
- Peak and Voltage Issues

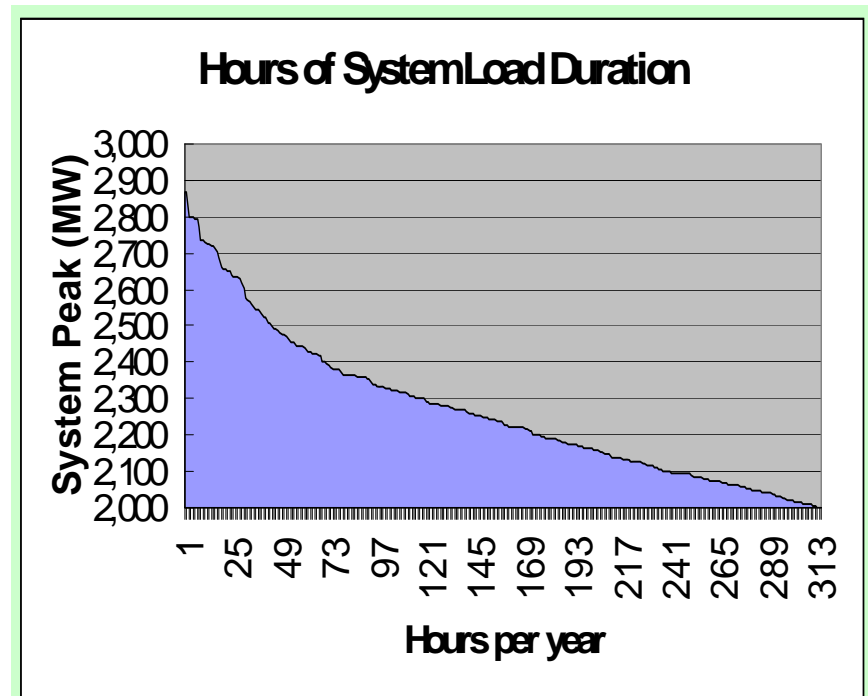

**SMUD**

SACRAMENTO MUNICIPAL UTILITY DISTRICT

The Power To Do More.<sup>SM</sup>

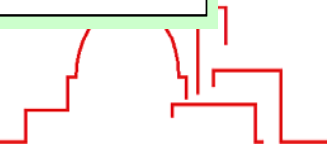



# Premier Gardens Distribution System Study 2006-07

- Distribution system-level and system-level impact of two subdivisions:
  - **Cresleigh Homes-** SMUD Advantage Home Gold features (30% reduction in cooling energy)
  - **Premier Gardens** – SolarSmart requirements (2.03 kW PV)
- Performance data collected from:
  - 15 minute demand, generation, and voltage data on 18 Cresleigh Homes and 18 Premier Gardens homes
  - Secondary current, voltage, and power at each of two distribution transformers
  - Voltage, current, and power on circuit 1204 (one of two feeders that supply the development) at Goethe-Mayhew substation



**SMUD**

SACRAMENTO MUNICIPAL UTILITY DISTRICT

The Power To Do More.<sup>SM</sup>

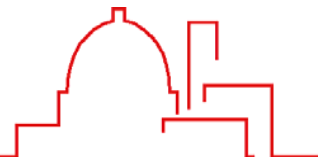

# Premier Gardens PV System

95-unit ZEH subdivision

- 50-60% > 01 T-24
- 2.03 kW<sub>AC</sub> PV System
  - 48 GE Energy GT 55 BIPV Modules, SMA 2500 Inverter

98-unit Cresleigh Homes

- 20% > 01 T-24 (30% Cooling Energy Savings), Non-PV
- 750kW peak demand
- Served by 12.5MVA/12.47kV/substation transformer
- <10% of the load served by the substation transformer



**SMUD**

SACRAMENTO MUNICIPAL UTILITY DISTRICT

The Power To Do More.<sup>SM</sup>



# Diagram of Primary Distribution System

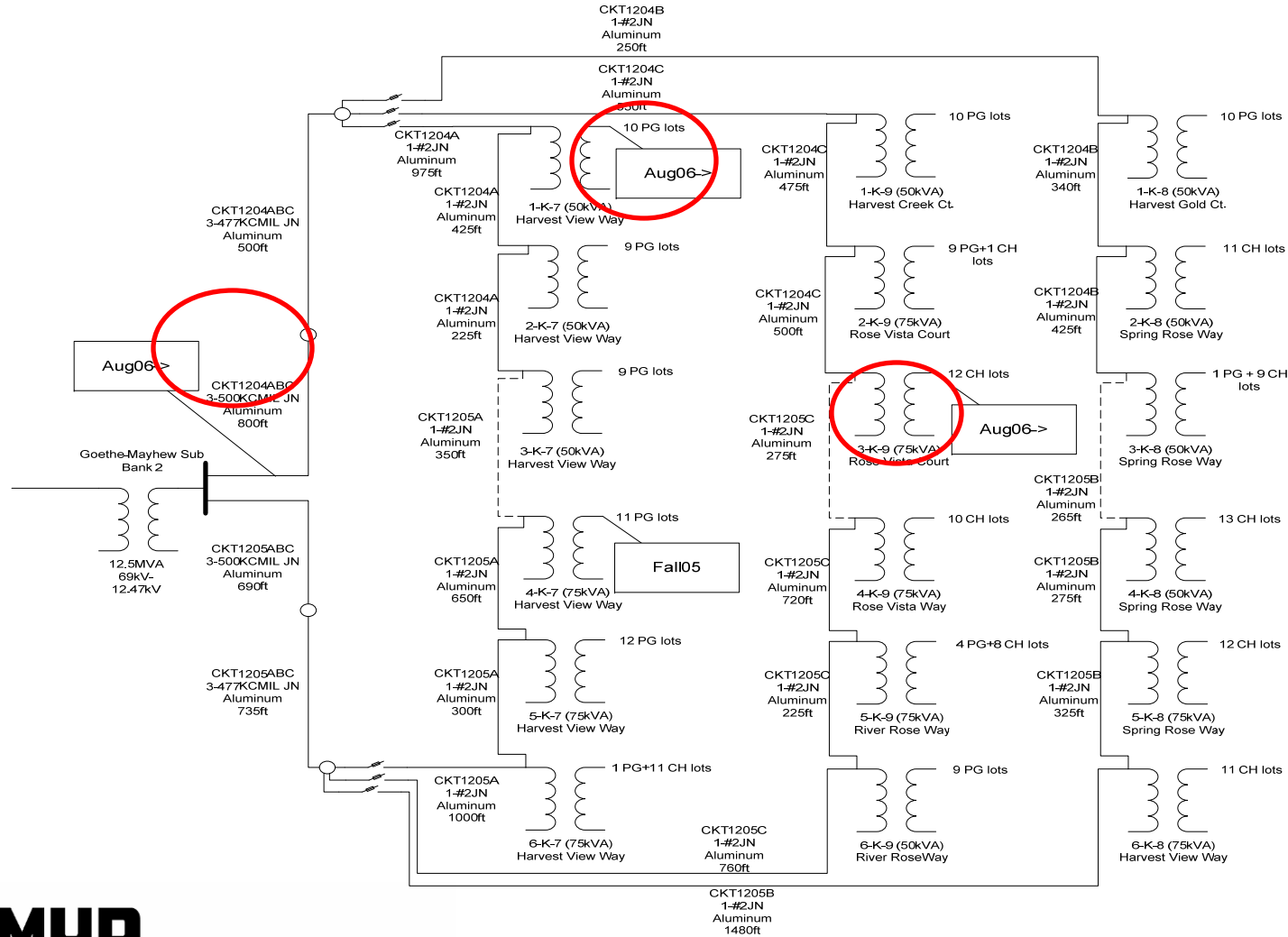

**SMUD**

SACRAMENTO MUNICIPAL UTILITY DISTRICT

The Power To Do More.<sup>SM</sup>

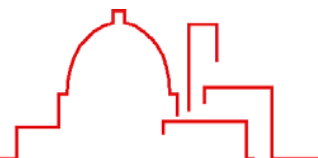

# Premier Gardens Load Data

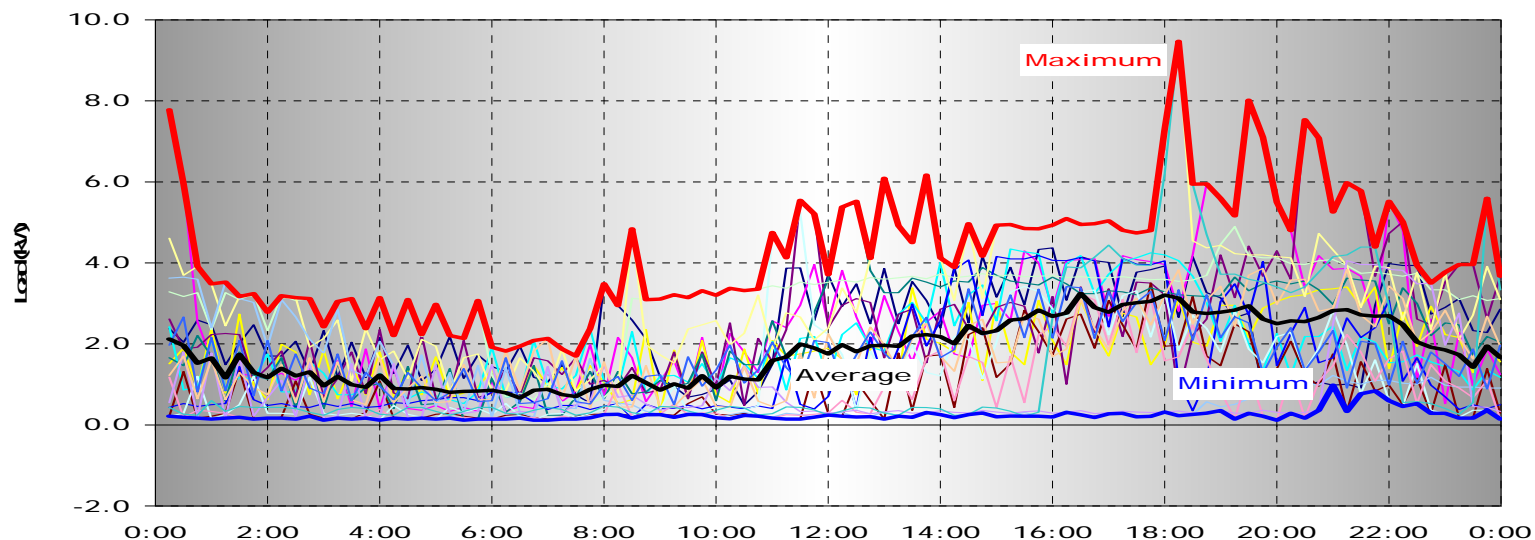

- 15 min load for 18 homes
- Individual customer loads highly volatile
  - Red represents max for all homes
  - Blue is min.
- Average resembles system wide profile



**SMUD**

SACRAMENTO MUNICIPAL UTILITY DISTRICT

The Power To Do More.<sup>SM</sup>



# PV Generation Profile

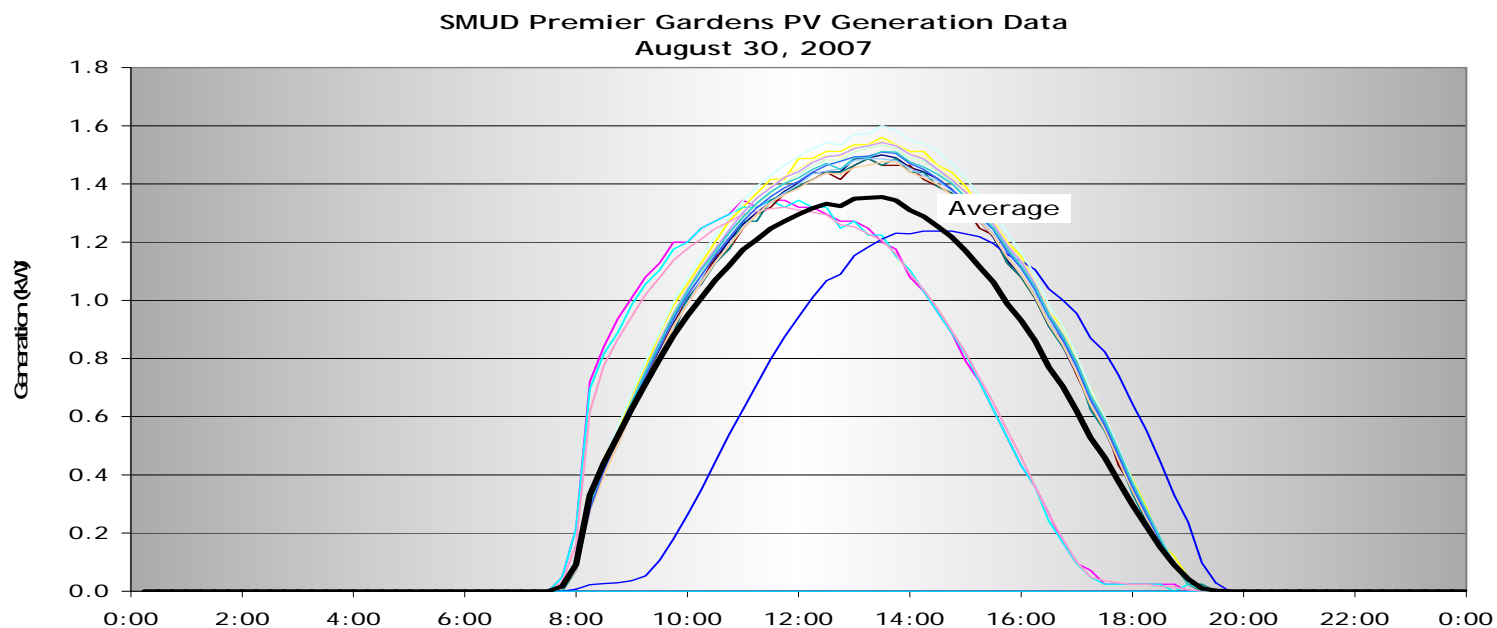

- 15 min PV output for 18 homes
- South, SW, SE orientations evident
- Average is lower peak but slightly broader output than individual



**SMUD**

SACRAMENTO MUNICIPAL UTILITY DISTRICT

The Power To Do More.<sup>SM</sup>



# Premier Gardens Net Demand

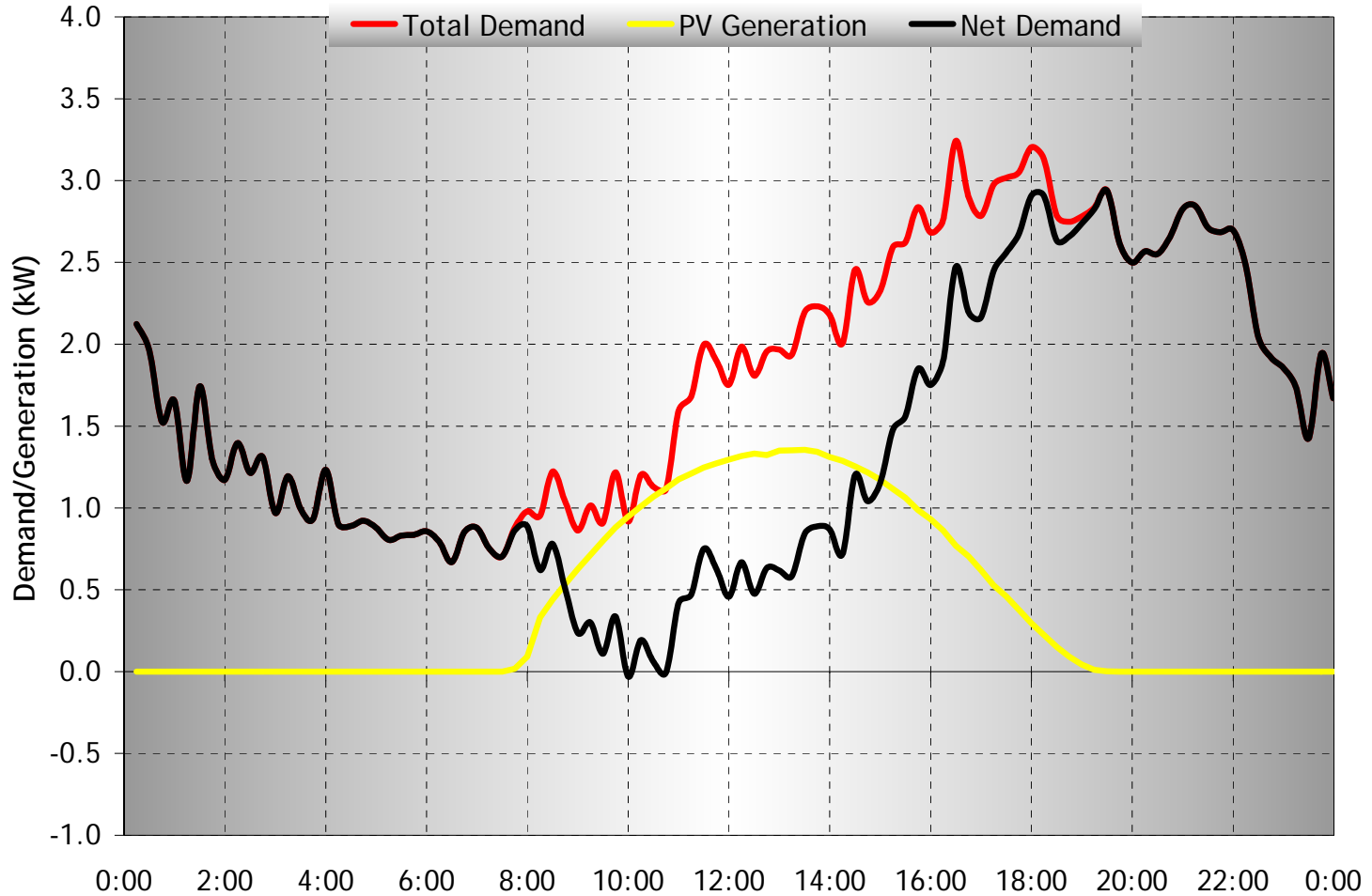

- Average per House Total Demand, PV Output, and Net Demand
- Peak Demand is reduced and move back about 1:30



**SMUD**

SACRAMENTO MUNICIPAL UTILITY DISTRICT

The Power To Do More.<sup>SM</sup>

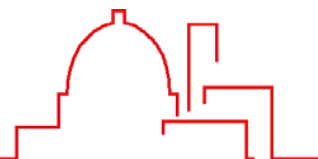

# Feeder 1204 Demand Profile

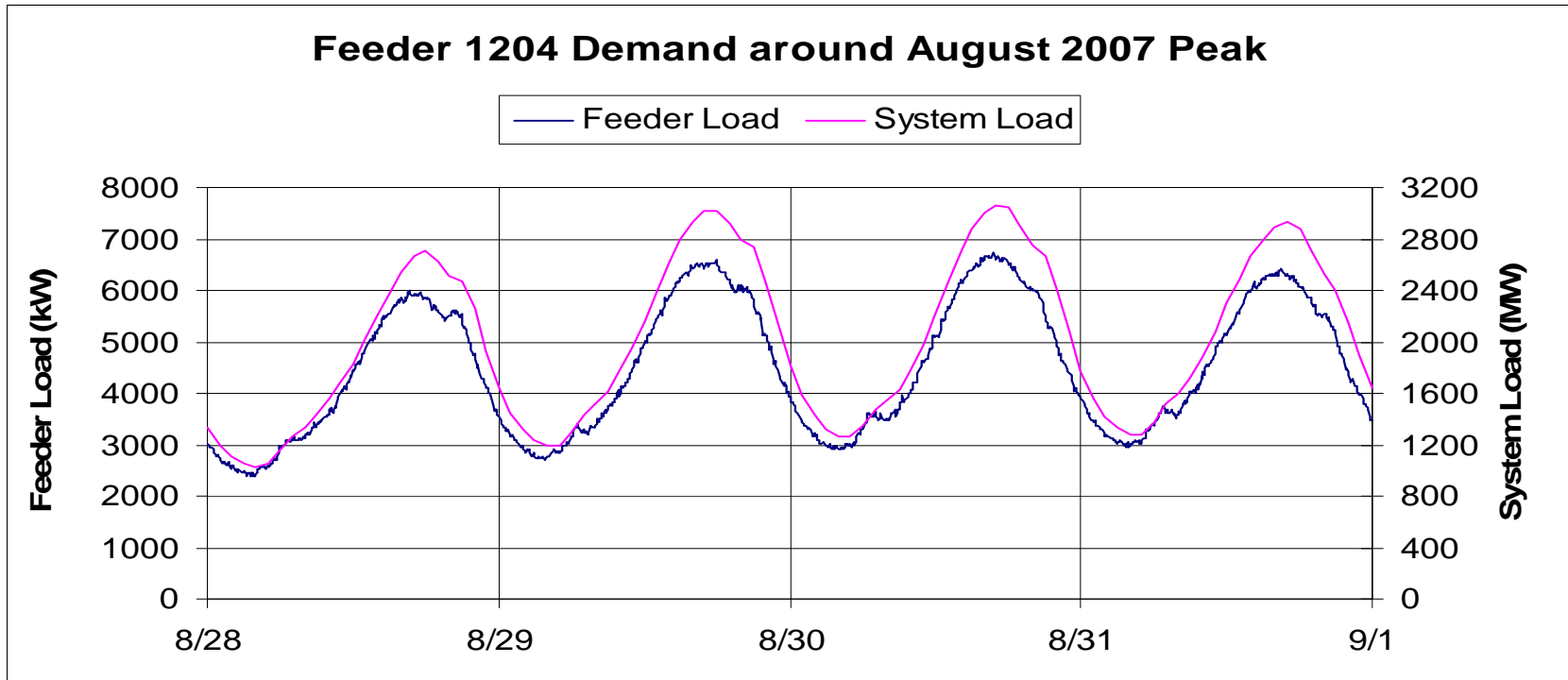

- Real power demand at feeder is diverse (smooth)
- Local feeder Peak time is similar to system peak
  - Residential peak is usually later than system peak



**SMUD**

SACRAMENTO MUNICIPAL UTILITY DISTRICT

The Power To Do More.<sup>SM</sup>

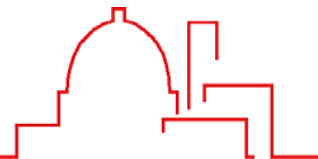

# Voltage at the Substation

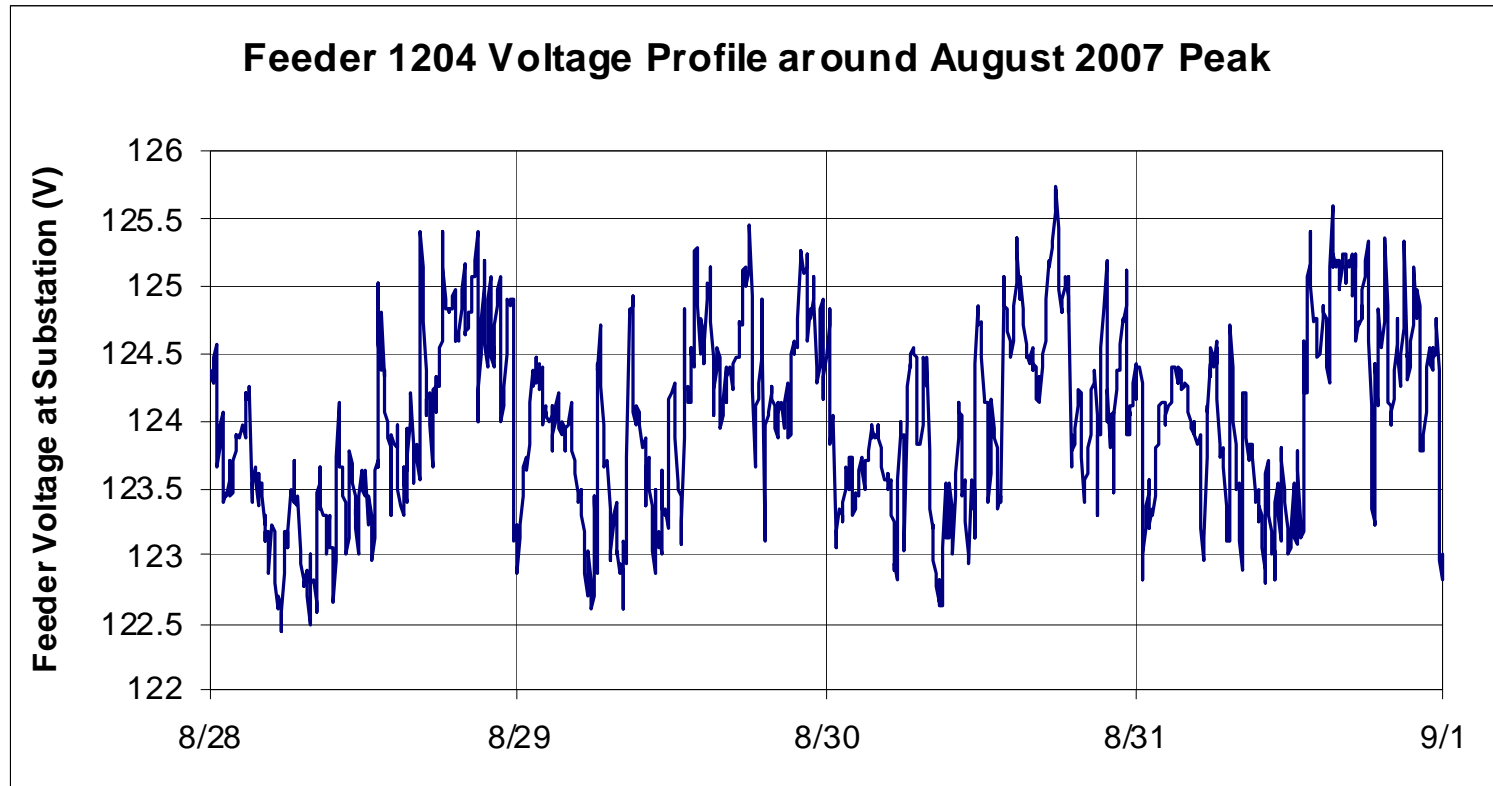

- Random voltage in short term
- Voltage trend rises due to LTC action around evening peak



**SMUD**

SACRAMENTO MUNICIPAL UTILITY DISTRICT

The Power To Do More.<sup>SM</sup>

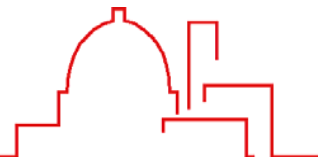

# Single Phase Substation Voltage (120V Basis) vs. Current

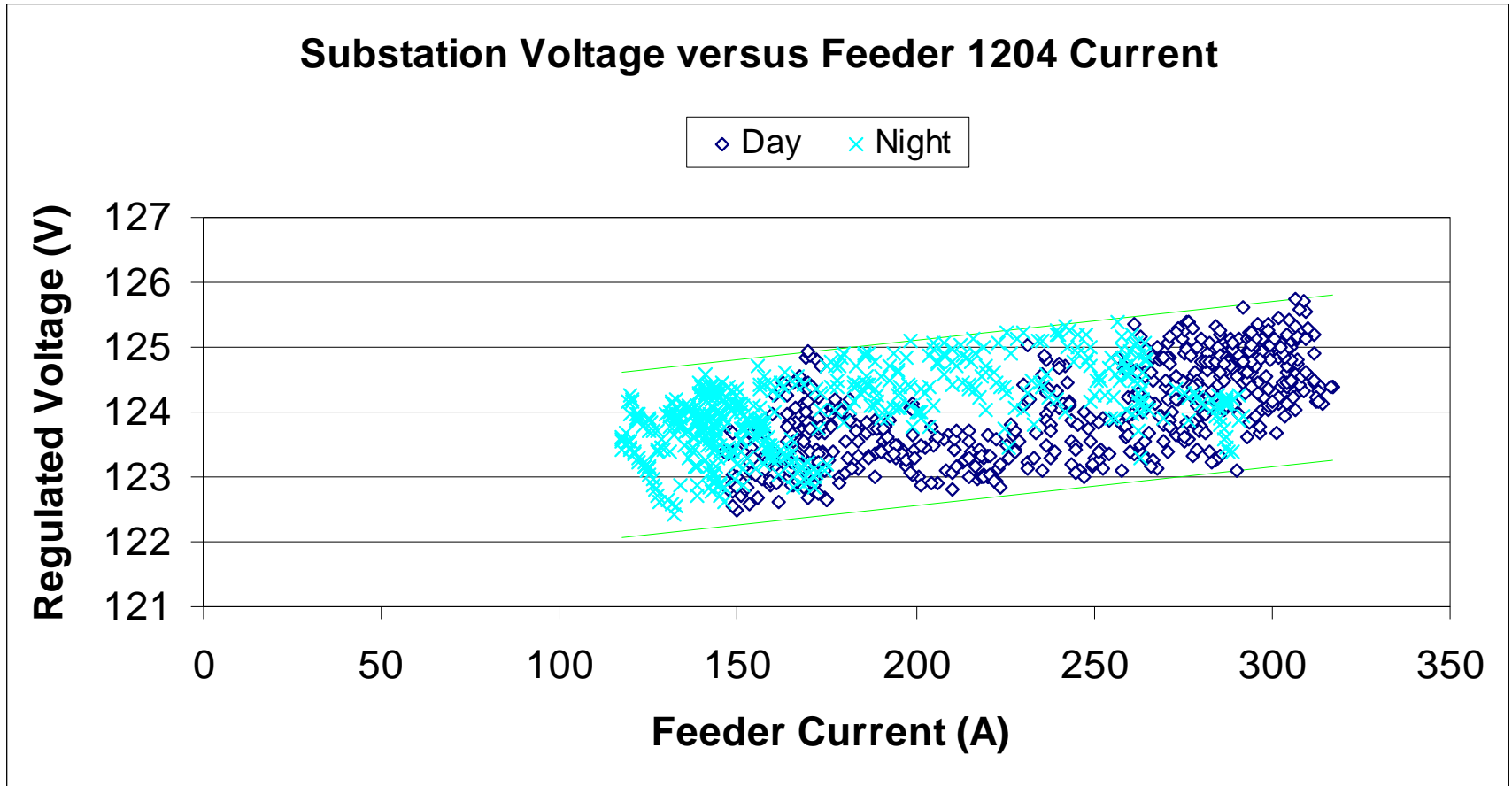

**SMUD**

SACRAMENTO MUNICIPAL UTILITY DISTRICT

The Power To Do More.<sup>SM</sup>



# Voltage and Demand at 1K7 Premier Gardens Distribution Transformer

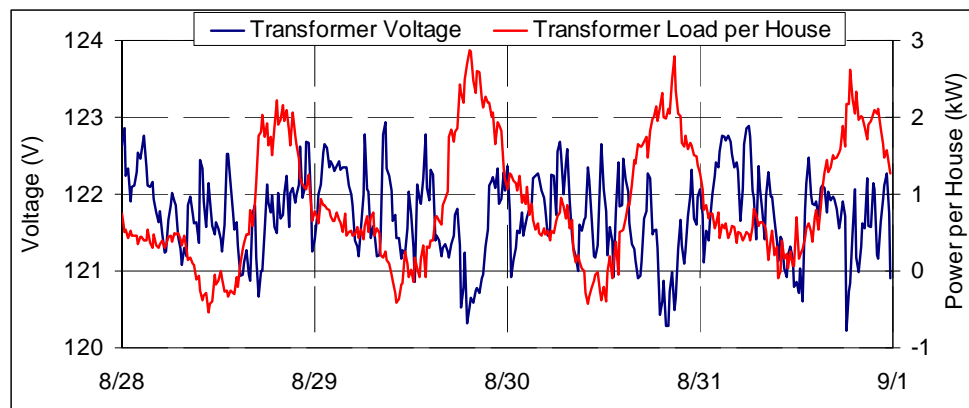

- Voltage drops in afternoon as demand rises
- Small reverse power flow at midday
  - More reverse power flow in Spring when loads are lower



**SMUD**

SACRAMENTO MUNICIPAL UTILITY DISTRICT

The Power To Do More.<sup>SM</sup>



# Voltage Rise in the Secondary Wiring

Cresleigh Homes

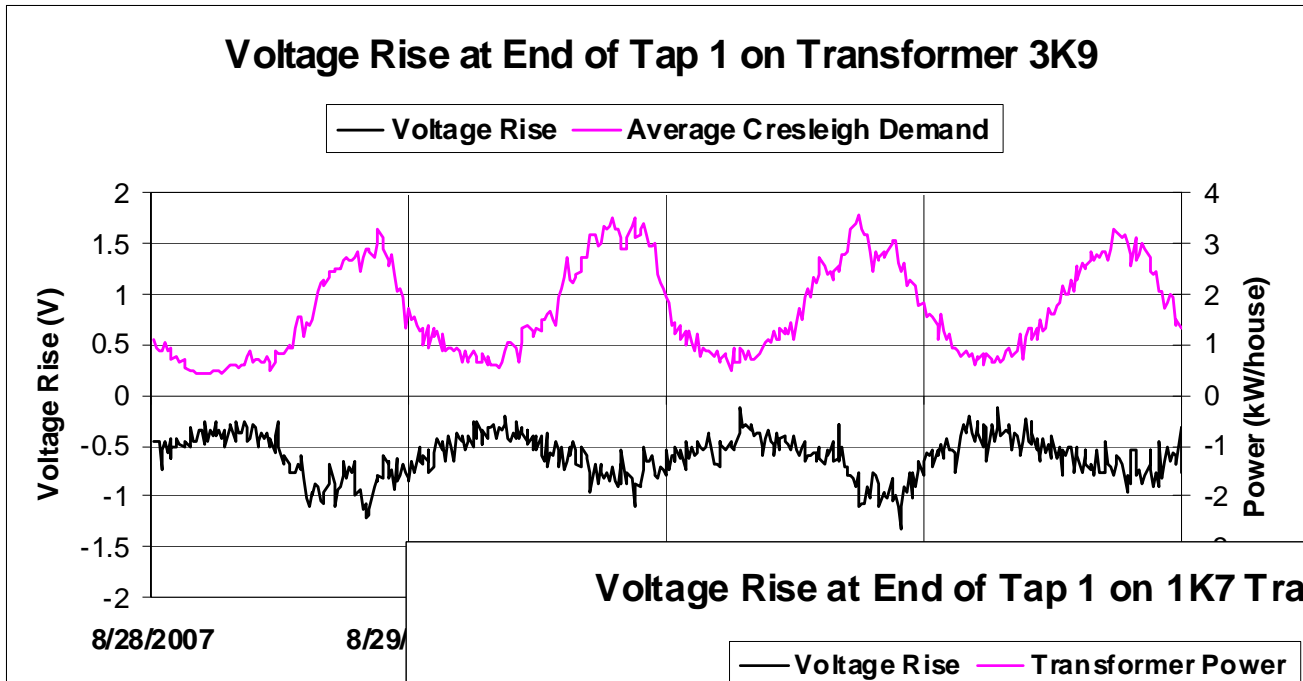

Premier Gardens

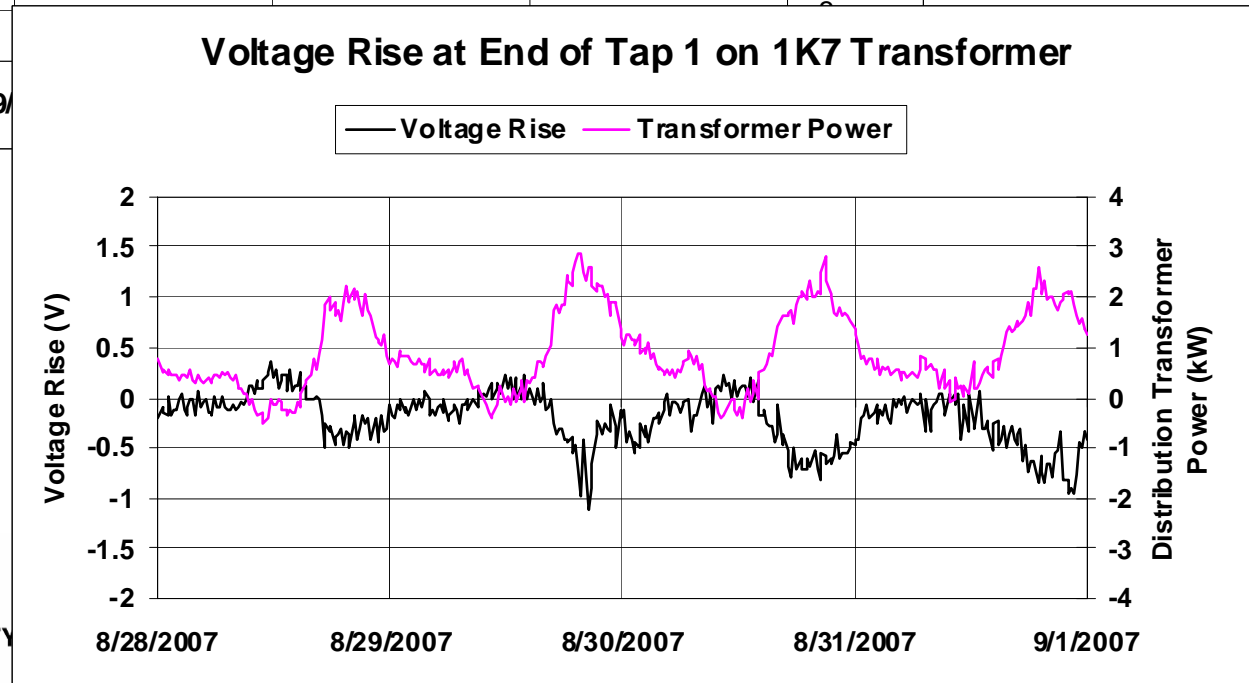

**SMUD**

SACRAMENTO MUNICIPAL UTILITY DISTRICT

The Power To Do More.<sup>SM</sup>

# Voltage Rise at End of Tap on Premier Gardens Transformer 1K7

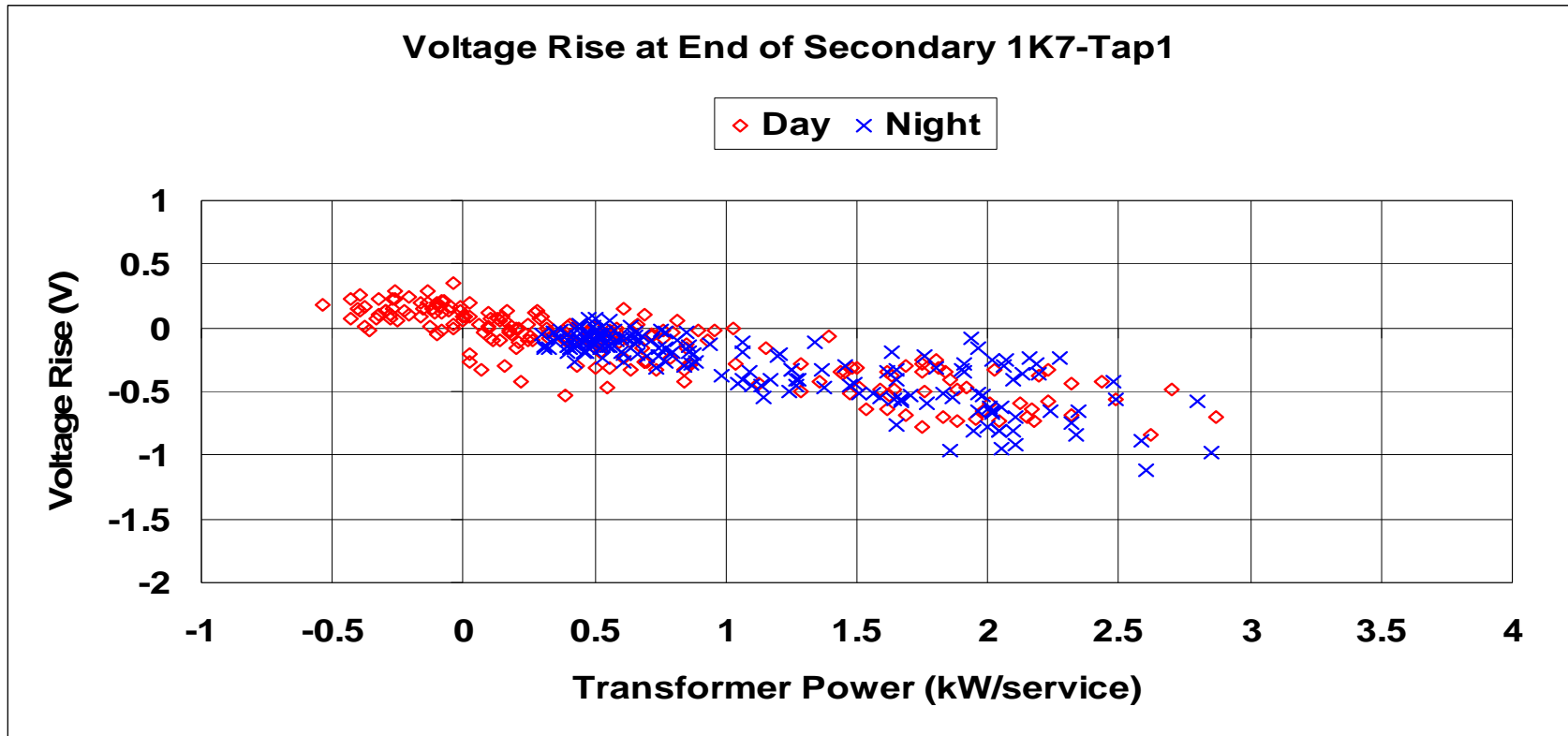

**SMUD**

SACRAMENTO MUNICIPAL UTILITY DISTRICT

The Power To Do More.<sup>SM</sup>

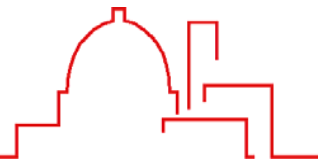



# Voltage Impacts on Distribution System

- PV output from Premier Gardens (190kW of PV, 6MW feeder = 3.1% penetration) had an indiscernible impact on substation voltage
  - voltage regulation action of the substation load tap changer.
- 50 kW distribution transformer with 20.3kW of PV (40% penetration) showed a relatively benign voltage rise ( $0.2V / 120V = 0.16\%$ ).



**SMUD**

SACRAMENTO MUNICIPAL UTILITY DISTRICT

The Power To Do More.<sup>SM</sup>

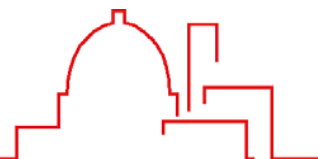

# July 2007 Estimated Solar Contribution

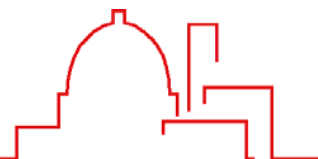
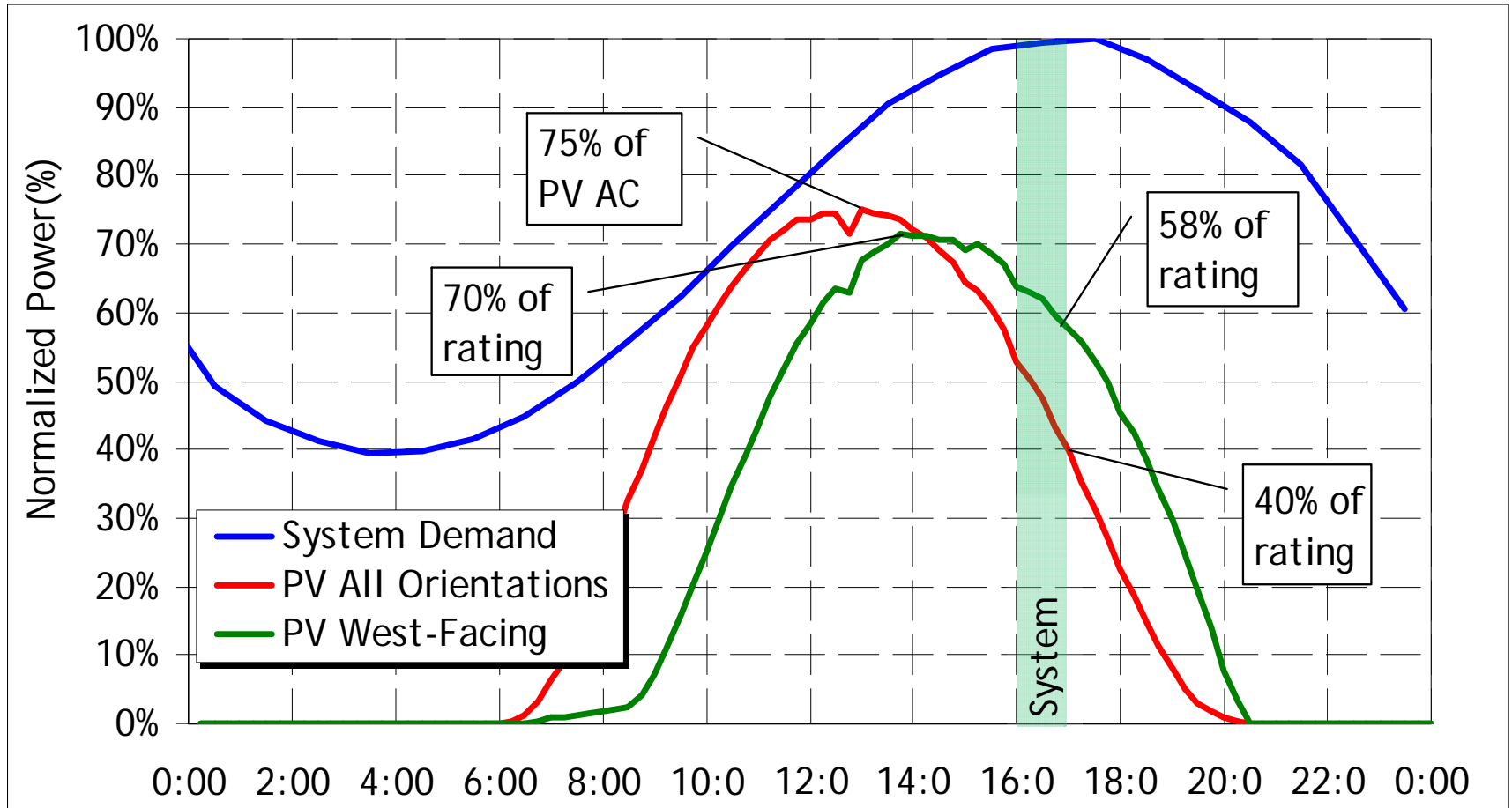

# Impacts on System Peak Demand

- 40% - 53% of rated PV output during July system peak (17:00)
- 33% - 51% of rated output for the August peak (17:00)
- West-facing system would produce less annual energy but would be more optimally oriented for afternoon sun producing:
  - 58% - 64% of rated output during the July system peak
  - 56% - 66% of rated output during the August peak
- Significant amount of PV capacity available to address system peak demand
  - can be roughly translated to system-wide production for fixed orientation PV systems



**SMUD**

SACRAMENTO MUNICIPAL UTILITY DISTRICT

The Power To Do More.<sup>SM</sup>

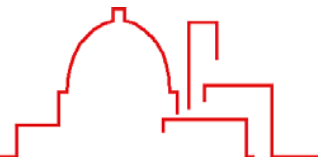



# Conclusions

- Distribution system impacts were non-existent
  - Minimal voltage rise at the substation and transformers
- Potential for significant system peak demand reduction
  - 40-58% of rated PV capacity @ system peak
  - PV capacity is still growing



**SMUD**

SACRAMENTO MUNICIPAL UTILITY DISTRICT

The Power To Do More.<sup>SM</sup>

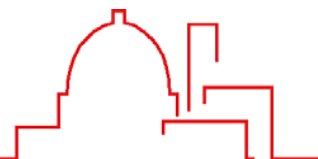

# Joint NREL/SMUD Anatolia Research Project

- 2 year study begun March, 2008 to evaluate impacts and benefits high penetrations of residential PV systems:
- 795-home community will have 600+ SolarSmart Homes, each with ~ 2.0 -5.0 kW<sub>ac</sub> PV system (only 240 homes built, so far)
- Analyze distribution impacts of high penetrations of grid-integrated PV-equipped SolarSmart Homes
  - reverse power flow from exporting PV systems
  - Peak impacts



**SMUD**

SACRAMENTO MUNICIPAL UTILITY DISTRICT

The Power To Do More.<sup>SM</sup>

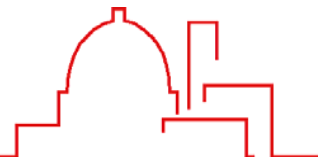

# SolarSmart Homes

- High Efficiency (60%> T-24) + PV
  - 50-70%+ reduction in annual electric consumption
  - 20-25% reduction in annual gas use
- Package of Efficiency Measures
  - Radiant barrier
  - 90 AFUE Furnace
  - SEER 14/ EER 12 AC.
  - Compact fluorescent lighting:
  - ENERGY STAR windows:
  - Third-party testing & certification
- Typical PV systems
  - 2.0 kW ac 36 SunPower 63-watt SunTile roof-integrated modules powering a SunPower SPR-2800x inverter
  - Optional to 5 kW



**SMUD**

SACRAMENTO MUNICIPAL UTILITY DISTRICT

The Power To Do More.<sup>SM</sup>

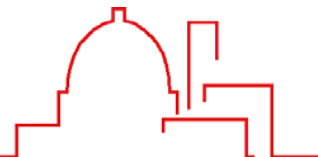

# System Pictures and Monitoring Points

- 3-7 km circuit lengths
- Served by 20 MVA/12.47kV substation transformer

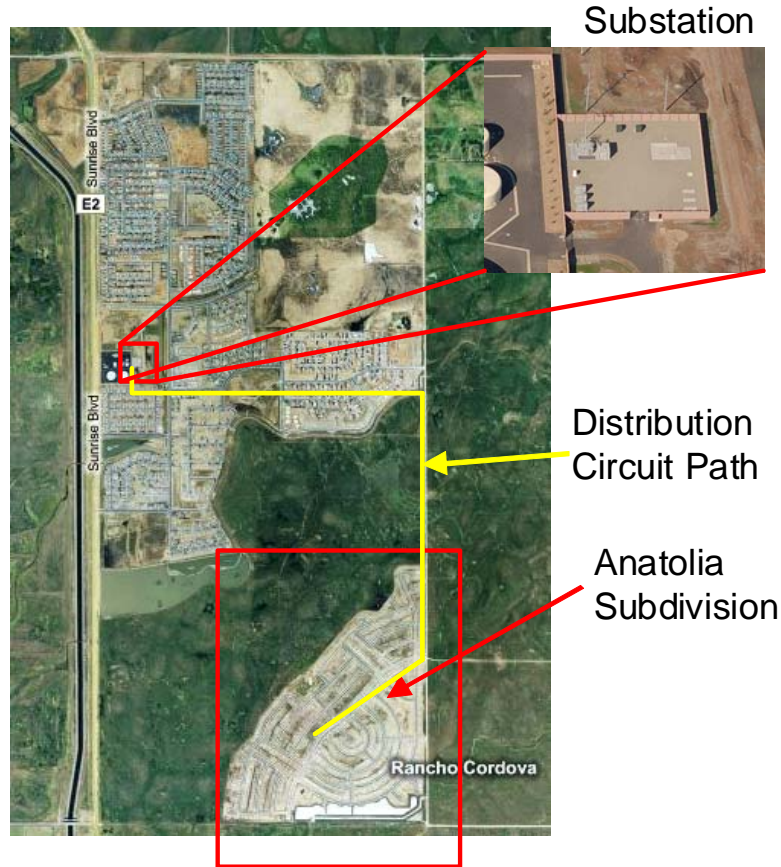

**SMUD**

SACRAMENTO MUNICIPAL UTILITY DISTRICT

The Power To Do More.<sup>SM</sup>



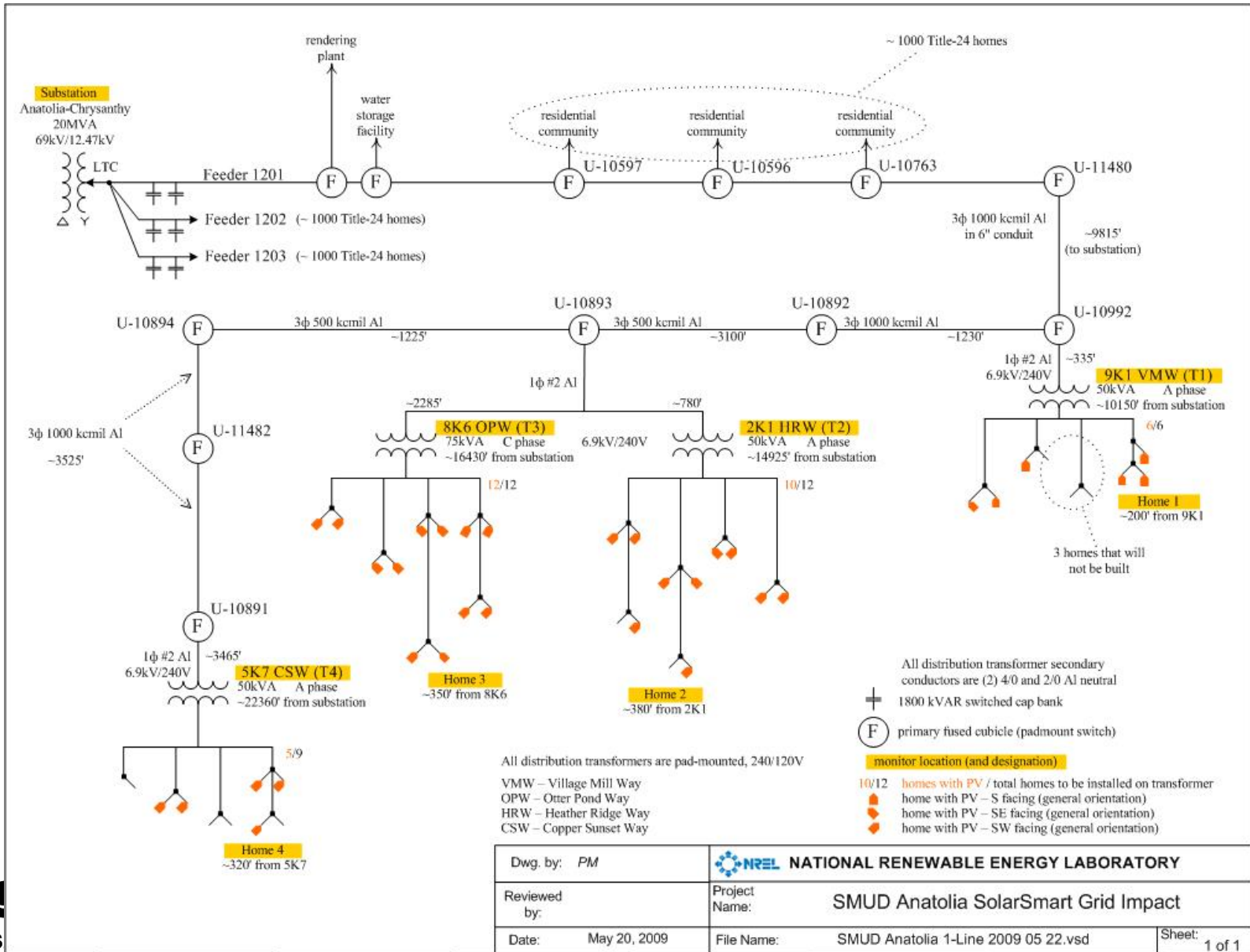

|                    |                                      |                                      |
|--------------------|--------------------------------------|--------------------------------------|
| Dwg. by: PM        | NATIONAL RENEWABLE ENERGY LABORATORY |                                      |
| Reviewed by:       | Project Name:                        | SMUD Anatolia SolarSmart Grid Impact |
| Date: May 20, 2009 | File Name:                           | SMUD Anatolia 1-Line 2009 05 22.vsd  |
|                    |                                      | Sheet: 1 of 1                        |

# Anatolia Results - Voltage

Voltage at Substation, Transformer 3 and Home 3

Clear, Cool Day

Saturday, 7 March 2009

17 deg C

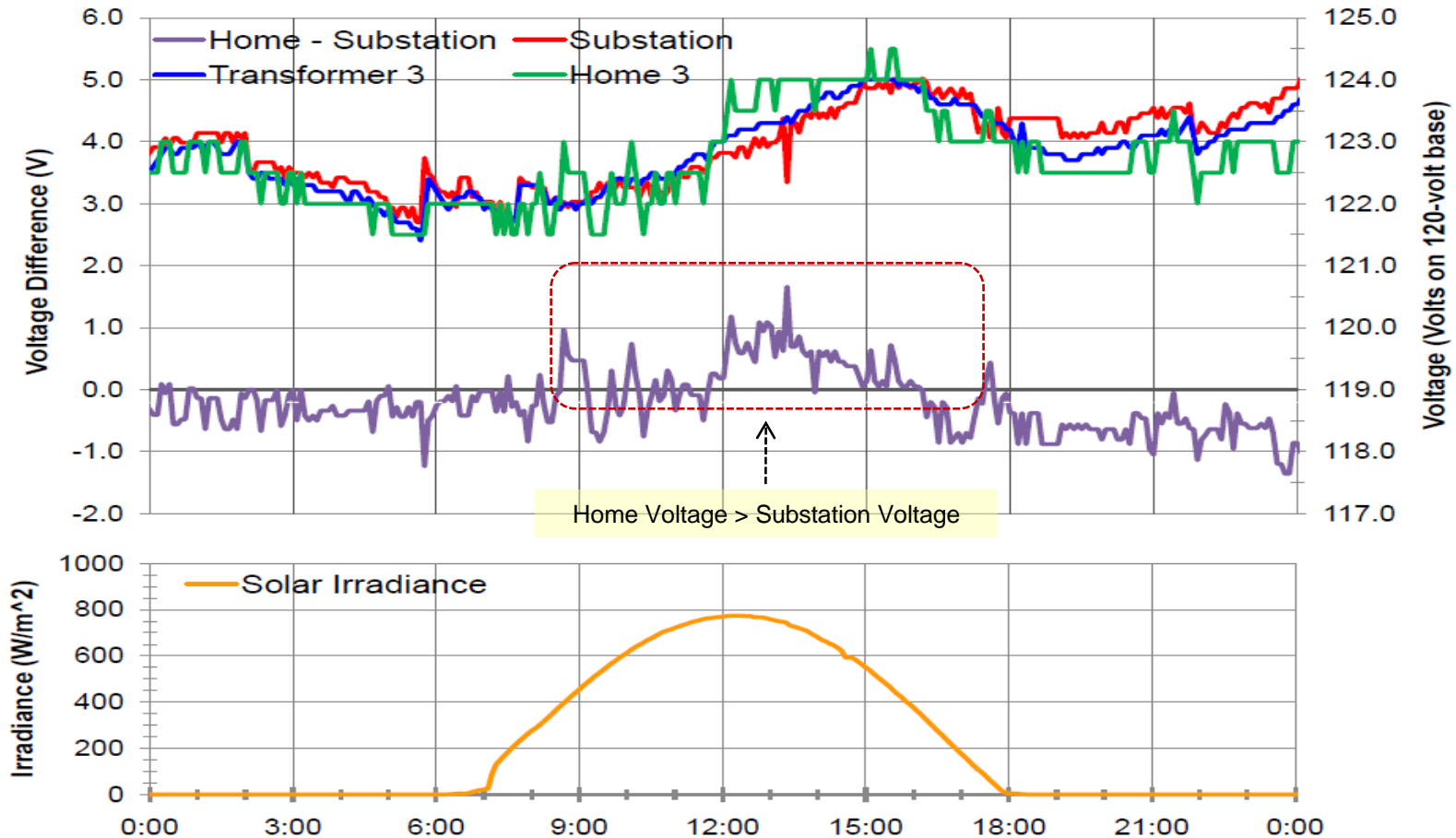

**SMUD**

SACRAMENTO MUNICIPAL UTILITY DISTRICT

The Power To Do More.<sup>SM</sup>



# Anatolia Results - Power

Real Power at Substation, Transformer 3 and Home 3  
 Clear, Cool Day Saturday, 7 March 2009 17 deg C  
 relatively light utility load and relatively high PV production

SMUD  
 Peak  
 Period  
 4-7 pm

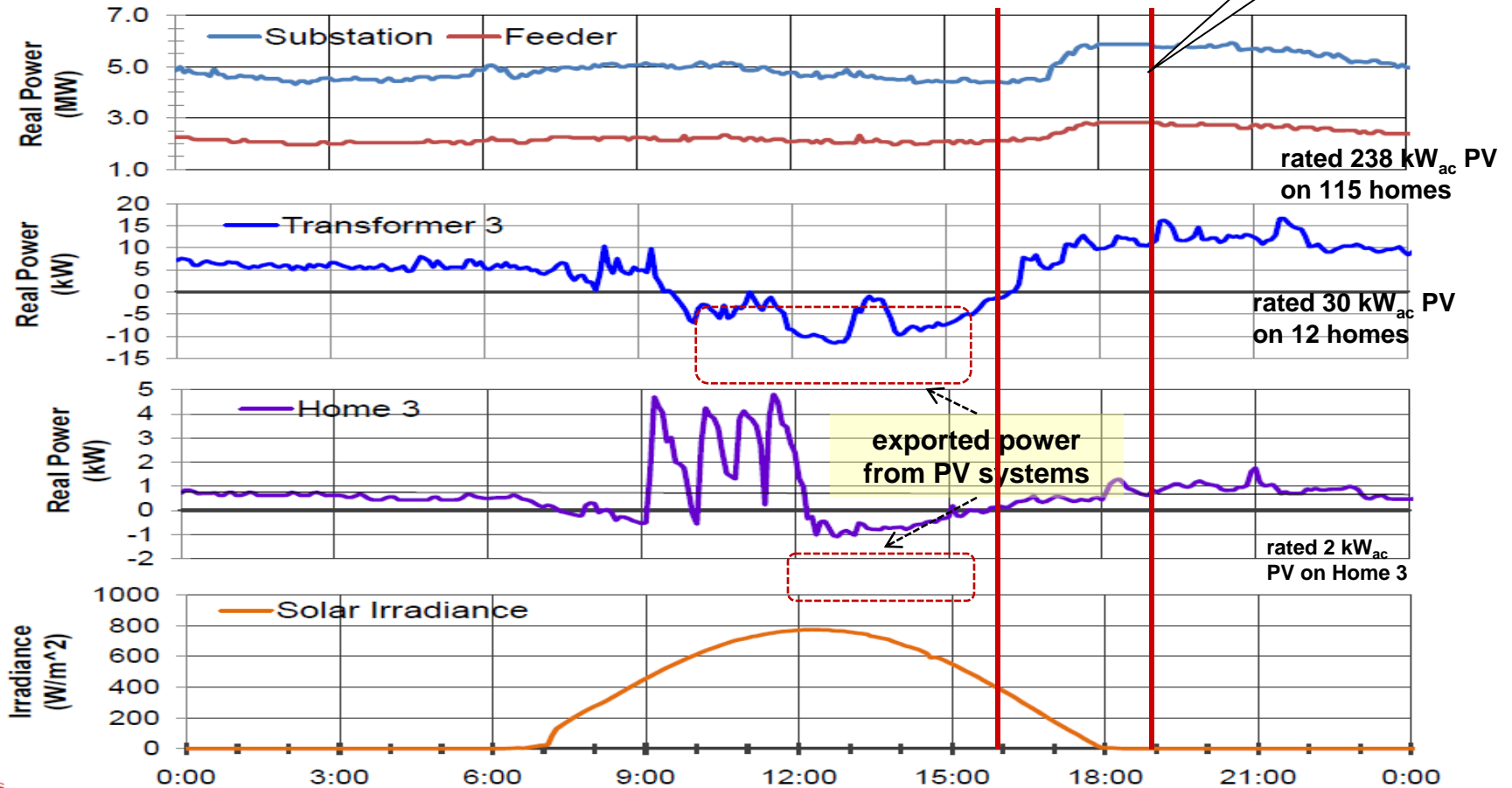

SACRAMENTO MUNICIPAL UTILITY DISTRICT

The Power To Do More<sup>SM</sup>



# Peak Impacts

## 4<sup>th</sup> Day of 6 Day Heat Storm 104°

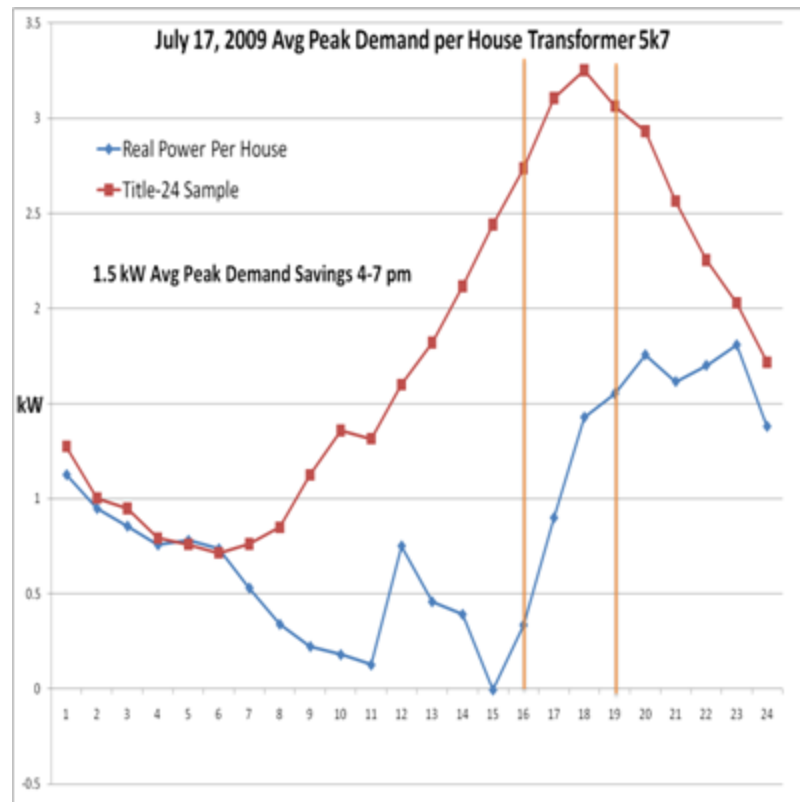
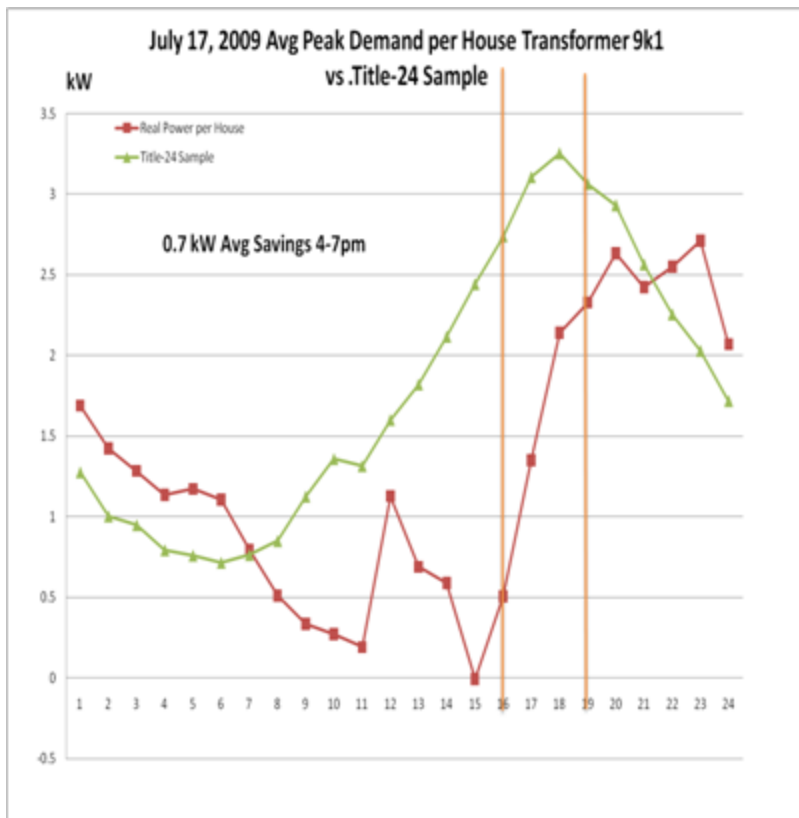

**SMUD**

SACRAMENTO MUNICIPAL UTILITY DISTRICT

The Power To Do More.<sup>SM</sup>

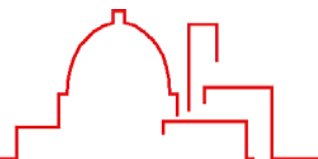

# Peak Impacts

## 6<sup>th</sup> Day of Heat Storm 106°

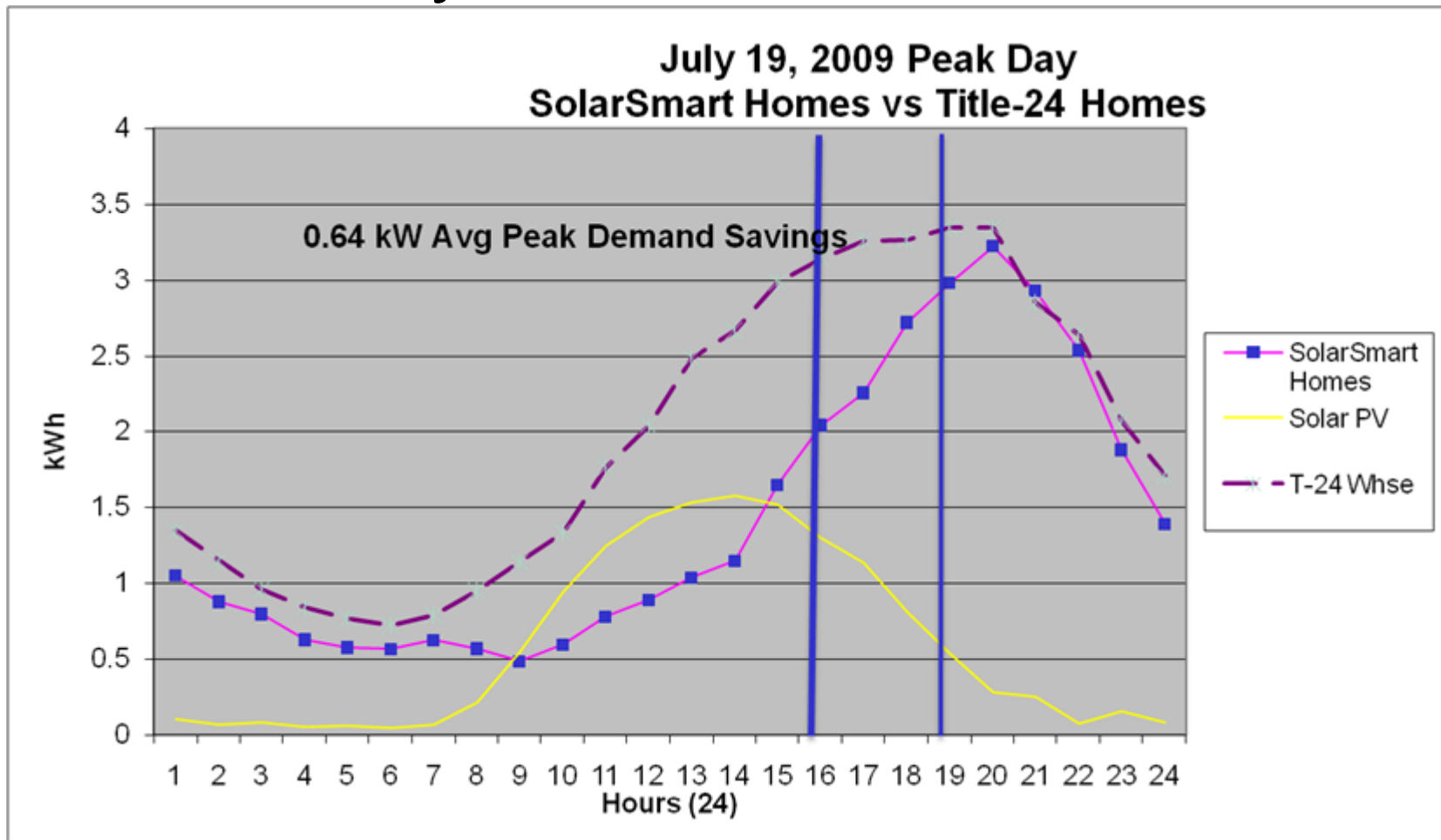

**SMUD**

SACRAMENTO MUNICIPAL UTILITY DISTRICT

The Power To Do More.<sup>SM</sup>



# Results to Date

- PV penetration levels on the feeder were no greater than 13% under lightly-loaded conditions (2.0 MW) and about 4.0% of the total substation transformer load
- There was no excessive service or substation voltage due to reverse power flow from exporting PV systems
- It was possible to see the effects of the PV systems on the voltage at the individual homes and the distribution transformers
- **PV systems have not adversely affected voltage regulation**
- **Large Potential Peak Demand Savings**
- The model will be used to determine acceptable levels of PV penetration



**SMUD**

SACRAMENTO MUNICIPAL UTILITY DISTRICT

The Power To Do More<sup>SM</sup>

National Renewable Energy Laboratory



Innovation for Our Energy Future

# FINAL THOUGHTS

- Hi-Eff/PV equipped homes can dramatically reduce Peak Demand.
- PV is a potential peak resource.
- Utilities need to examine and analyze PV impact on their own systems.
  - Monitor @ Substation, transformer, home/business
- Smart Grid Implications
  - Monitoring @ transformer issues



**SMUD**

SACRAMENTO MUNICIPAL UTILITY DISTRICT

The Power To Do More.<sup>SM</sup>

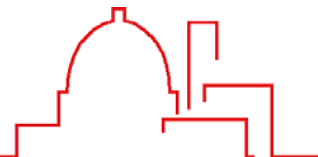

# SMUD PV & Smart Grid Pilot at Anatolia

## ARRA FOA 85 Topic 4: High Penetration Solar Development

Residential Energy Storage (RES) Group: Grid Tied with Battery Storage

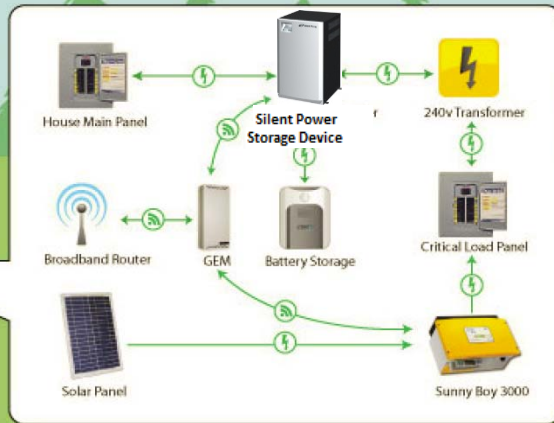

Community Energy Storage (CES) Group: Grid Tied with Battery Storage

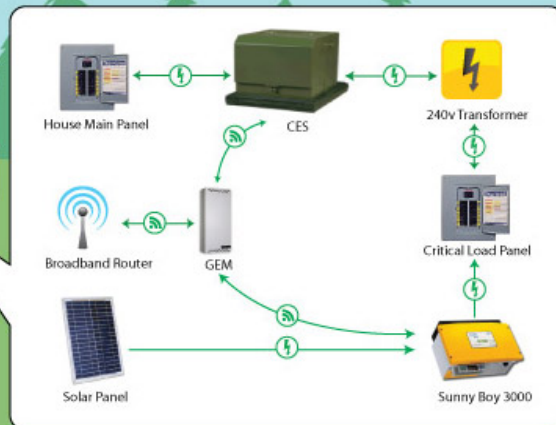

- Installing 15 RES and 3 CES units
- Will firm renewables, reduce peak load and improve reliability
- Partners include GridPoint, SunPower, Navigant, NREL, SAFT (lithium ion)
- Installing utility and customer portals to monitor PV, storage, customer load
- Sending price signals to affect changes in customer usage
- Quantifying costs and benefits of this storage deployment to gain insights to broader application for SMUD

### Inverter Communications

- Demonstrate inverter monitoring via AMI communication from smart meter to inverter
- Demonstrate receiving data, querying for faults, sending control signals
- Utilized as actively controlled contributors versus passive devices on the grid



National Renewable Energy Laboratory

A national laboratory of the U.S. Department of Energy  
Office of Energy Efficiency & Renewable Energy

*Innovation for Our Energy Future*

## Impact of SolarSmart Subdivisions on SMUD's Distribution System

Technical Report  
NREL/TP-550-46093  
July 2009

Peter McNutt and Joshua Hambrick  
*National Renewable Energy Laboratory  
Golden, Colorado*

Michael Keesee and David Brown  
*Sacramento Municipal Utility District  
Sacramento, California*

NREL is operated for DOE by the Alliance for Sustainable Energy, LLC Contract No. DE-AC36-08-GO28308



**SMUD**

SACRAMENTO MUNICIPAL UTILITY DISTRICT

The Power To Do More.<sup>SM</sup>



# ACKNOWLEDGEMENT

David Brown, Distribution Eng. SMUD

BEW Performed Technical Work on  
Premier Gardens

NREL Performed Technical Work On Anatolia  
Research is supported by the U.S. Department  
of Energy Solar Energy Technology Program



**SMUD**

SACRAMENTO MUNICIPAL UTILITY DISTRICT

The Power To Do More.<sup>SM</sup>

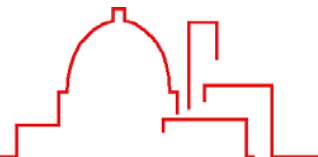

# Contacts

Michael Keesee, SMUD  
MKeesee@smud.org



**SMUD**

SACRAMENTO MUNICIPAL UTILITY DISTRICT

The Power To Do More.<sup>SM</sup>

