



EVALUATING FUTURE STANDARDS AND CODES WITH A FOCUS ON HIGH PENETRATION PHOTOVOLTAIC (HPPV) SYSTEM DEPLOYMENT

Michael Coddington,
Benjamin Kroposki,
Tom Basso, and Kevin Lynn (DOE)
Michael.Coddington@nrel.gov

Effectively interconnecting high-level penetration of photovoltaic (PV) systems requires careful technical attention to ensuring compatibility with electric power systems. Standards, codes, and implementation have been cited as major impediments to widespread use of PV within electric power systems.

On May 20, 2010, in Denver, Colorado, the National Renewable Energy Laboratory, in conjunction with the U.S. Department of Energy (DOE) Office of Energy Efficiency and Renewable Energy (EERE), held a workshop to examine the key technical issues and barriers associated with high PV penetration levels with an emphasis on codes and standards.

There was significant focus on future inverters that would be capable of staying online during grid anomalies while maintaining grid safety and reliability. Discussions included multiple definitions of high penetration, enhanced monitoring and control opportunities, and the new IEEE P1547.8 (Expanded Use of IEEE Standard 1547) that will focus on resolution of many concerns of high-penetration PV deployment.

DEFINING HIGH PENETRATION

- **Minimum Load to Generation Ratio:** this is the annual minimum load on the relevant power system section divided by the aggregate DG capacity on the power system section
- **Stiffness Factor:** the available utility fault current divided by DG rated output current in the affected area
- **Fault Ratio Factor:** available utility fault current divided by DG fault contribution in the affected area
- **Ground Source Impedance Ratio:** ratio of zero sequence impedance of DG ground source relative to utility ground source impedance)

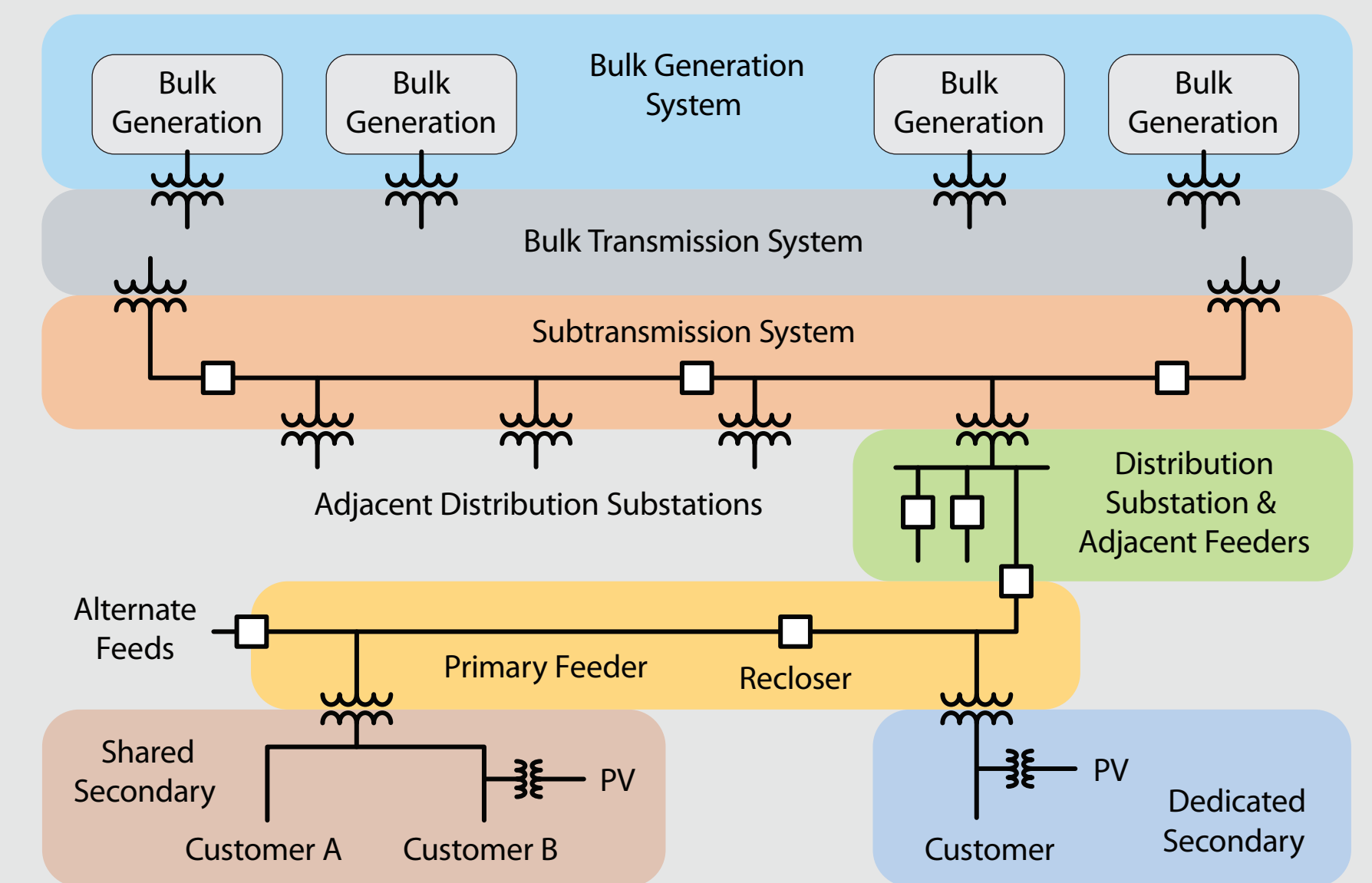

Type of Ratio	What is it useful for? <i>Note: these ratios are intended for distribution and subtransmission system impacts of DG listed below, and not necessarily the overall bulk system stability impact</i>	Suggested Penetration Level Ratios		
		Very Low Penetration <i>Very low probability of any issues</i>	Moderate Penetration <i>Low to minor probability of issues</i>	Higher Penetration <i>Increased probability of serious issues.</i>
Minimum Load to Generation Ratio	• Ground fault overvoltage analysis <i>(use ratios shown when DG is not effectively grounded)</i> • Islanding analysis <i>(use ratios 2/3 of those shown)</i>	> 10 <i>Synchronous Gen.</i>	10 to 5 <i>Synchronous Gen.</i>	Less than 5 <i>Synchronous Gen.</i>
		> 6 <i>Inverters</i>	6 to 3 <i>Inverters</i>	Less than 3 <i>Inverters</i>
Fault Ratio Factor $(I_{scUtility}/I_{scDG})$	• Overcurrent device coordination • Overcurrent device ratings	>100	100 to 20	Less than 20
Stiffness Factor $(I_{UtilitySC}/I_{RatedDG})$	• Voltage Regulation <i>(this ratio is a good indicator of voltage influence. Wind/PV have higher ratios due to their fluctuations. Besides this ratio, may need to check for current reversal at upstream regulator devices.)</i>	>100 <i>PV/Wind</i>	100 to 50 <i>PV/Wind</i>	Less than 50 <i>PV/Wind</i>
		> 50 <i>Steady Source</i>	50 to 25 <i>Steady Source</i>	Less than 25 <i>Steady Source</i>
Ground Source Impedance Ratio	• Ground fault desensitization • Overcurrent device coordination and ratings	>100	100 to 20	Less than 20

GRID-INTEGRATED SMART INVERTERS



Prism Solar PV Inverter
Manufactured by Satcon

- Connect / Disconnect from Grid
- Output Power Management
- Intelligent Volt-Var Control
- Storage Management
- Event/History Logging
- Status Reporting /Reading
- Time-sync

Advanced Volt-Var Control

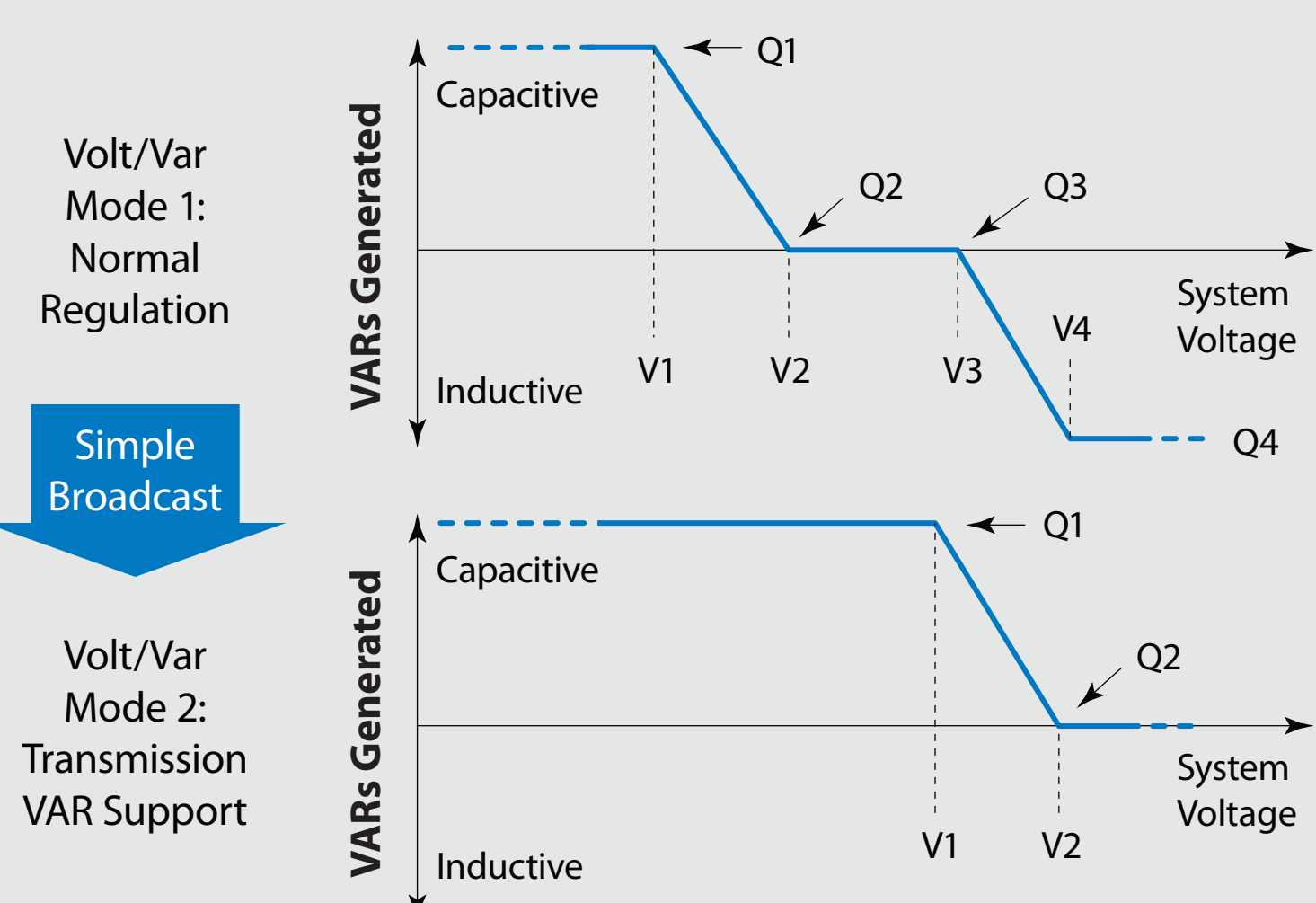

Effect on Service Voltage

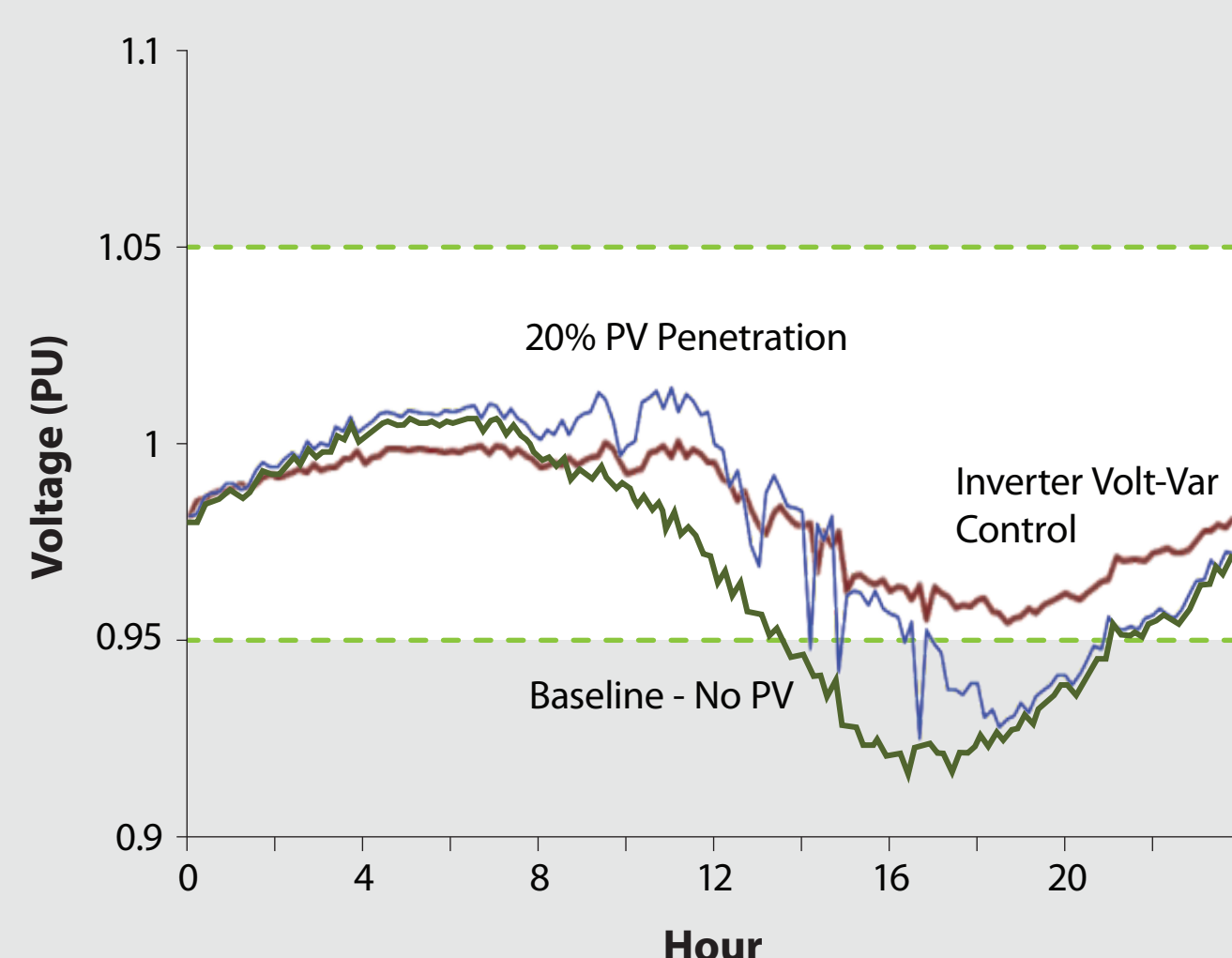

DYNAMIC CONTROL OF INVERTERS

TECHNICAL CHALLENGES

- Most of the changes can be done in software
- Minor hardware changes
 - Additional Sensors
 - UPS for LVRT
 - Minimal additional cost
- Inverter will operate at higher current levels when off of unity power factor than at unity
 - Impacts efficiency and reliability

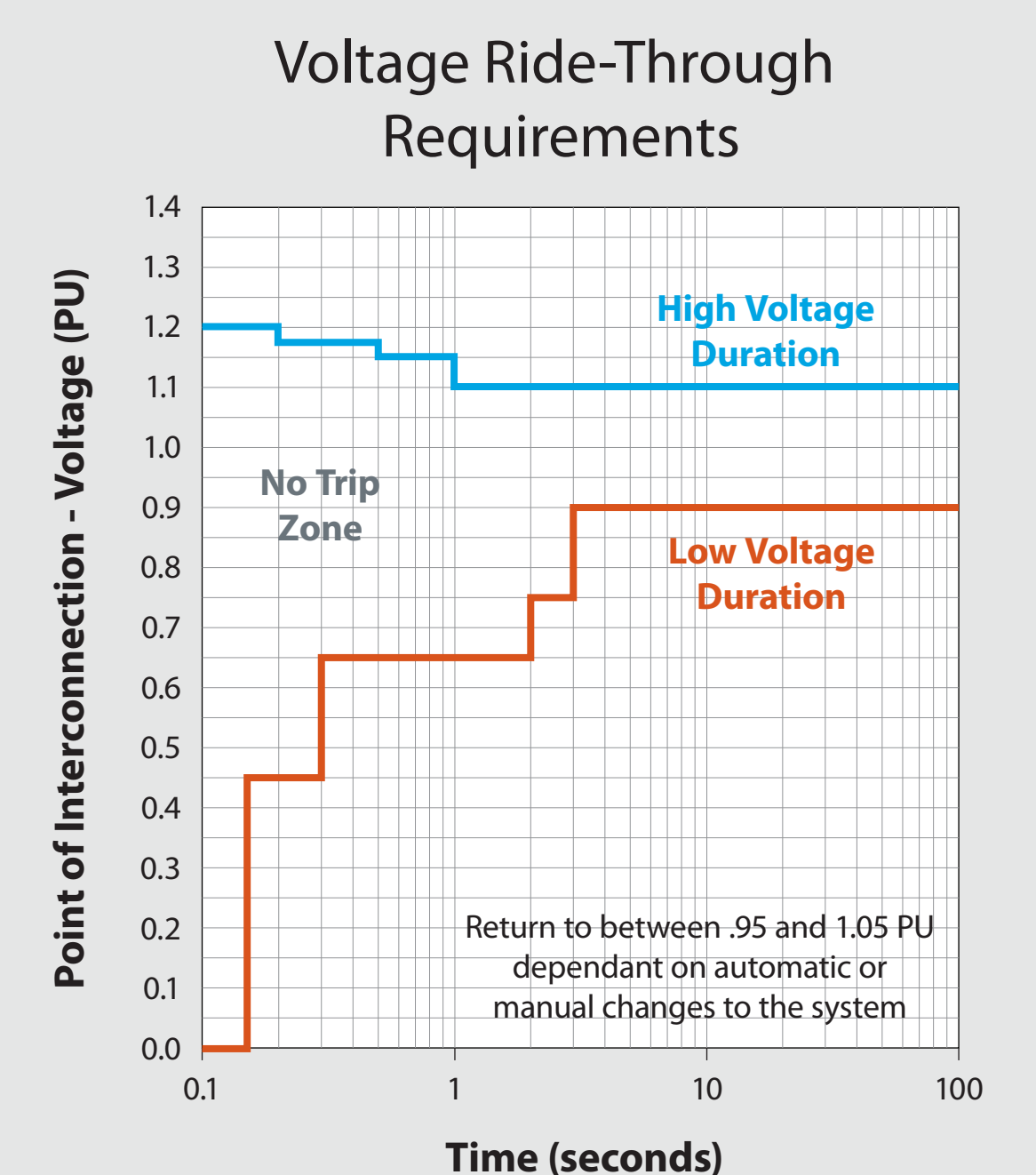

DYNAMIC CONTROL

- Communications to PV inverters to control operational setpoints
 - Real Power Limit
 - Curtail production!?
 - Ramp rates
 - Reactive Power Level
 - VARs
 - Power Factor
 - Voltage control
 - Trip levels
 - Over/Under Voltage
 - Over/Under Frequency
- Operate like traditional power plants

Frequency Ride-Through Requirements

